



## Regular Meeting of the Board of Directors

City of Texarkana, Arkansas

216 Walnut Street

**Agenda - Monday, May 15, 2023 - 6:00 PM**

Call to Order

Roll Call

Invocation given by Director Harris

Pledge of Allegiance led by David Carlton, Troop 86 Senior Patrol Leader

### **CITIZEN COMMUNICATION**

*A limit of five (5) minutes per person is allotted for citizens to express their concerns to the Board of Directors, with a maximum of fifty (50) minutes reserved for Citizens Communication. The Board of Directors cannot respond to citizens' concerns during this time.*

*Please fill out a Citizen Communication Card with your name and contact information for the City Clerk's records.*

### **PROCLAMATIONS**

1. Proclamation presented to Chief Michael Kramm for Police Appreciation Week, May 14-20, 2023. (CCD) City Clerk Heather Soyars
2. Proclamation presented to Public Works Director Tyler Richards for Public Works Appreciation Week, May 21-27, 2023. (CCD) City Clerk Heather Soyars

### **PRESENTATION**

3. Public Works Update. (PWD) Public Works Director Tyler Richards

### **CONSENT**

4. Approval of the minutes of the special called meeting at 12:00 PM on April 27, 2023, the regular meeting at 6:00 PM on May 1, 2023 and the special called meeting at 5:00 PM on May 8, 2023. (CCD) City Clerk Heather Soyars
5. Adopt a Resolution approving the reimbursement of \$10,335.33 to the Texarkana Regional Airport from American Rescue Act Funds. (FIN) Acting City Manager/Finance Director TyRhonda Henderson

6. Adopt a Resolution authorizing the Acting City Manager to enter into a contract with Artex Electric for the purchase and installation of poles and LED lighting at Field 1 of the Pondexter Sports Complex. (PARKS) Parks and Recreation Director Adam Dalby
7. Adopt a Resolution authorizing the Acting City Manager to enter into a Purchase Agreement with Ledwell & Son Enterprises, Inc., for a 2,000 Gallon Water Truck. (PWD) Public Works Director Tyler Richards
8. Adopt a Resolution declaring Public Works equipment surplus and authorizing disposal in accordance with Arkansas Law. (PWD) Public Works Director Tyler Richards
9. Adopt a Resolution authorizing the Acting City Manager to enter into a Construction Contract with Jack Yates Drywall, Inc., for the Rehabilitation of City Hall Restrooms. (PWD) Public Works Director Tyler Richards

## **REGULAR**

10. Adopt a Resolution approving the Airport Authority to enter into an agreement with the Yates Foundation, LLC., to name the new terminal the “Jim E. Yates Terminal”. (AIRPORT) Airport Director Paul Mehrlich
11. Adopt a Resolution to accept the proposed redistricting wards map. (ADMIN) Acting City Manager/Finance Director TyRhonda Henderson
12. Adopt an Ordinance authorizing the Board of Directors to amend Section 17-4 of the *City of Texarkana, Arkansas, Code of Ordinances* and provide for certain new fees for the rental and use of Front Street Festival Plaza. (PARKS) Parks and Recreation Director Adam Dalby  
*The applicant requests an emergency clause. An emergency clause requires a separate and distinct vote of the board and is valid only if there is a two-thirds vote of approval by the board. (Hdbk. Const. Amend 7)*

## **BOARD OF DIRECTORS' COMMENTARY**

## **EXECUTIVE SESSION**

**NEXT MEETING DATE: Monday, June 5, 2023**

## **ADJOURN**

### **2023 City Calendar**

Gateway Farmers Market - Open Tuesdays, Thursdays, Saturdays - 7AM- Noon  
Gateway Farmers Market First Responders Day - Saturday, May 20th - 7AM - Noon  
Be Like CJ 5K - Saturday, May 20th - 7:30AM - 10:30PM  
Gateway Farmers Market Grand Opening - Saturday, June 17th - 7AM - Noon  
Sesquicentennial Ball – July 8th  
Gateway Farmers Market National Farmers Market Week - Saturday, July 15th - 7AM - Noon

Gateway Farmers Market Salsa Contest - Saturday, August 5th - 7AM - Noon  
Gateway Farmers Market Fall Tailgates & Tables - Saturday, September 16th - 8AM - 2PM  
Gateway Farmers Market Holiday Market - Saturday, November 18th - 10AM - 2PM  
Founders' Week Celebration – December 4th – 10th

**Texarkana Rec Center Calendar**

Ageless Grace - Mondays – 2PM – 3PM  
Gym Open - Mondays, Wednesdays & Fridays – 8AM - 7PM & Saturdays - 8AM – Noon  
Dance Fitness - Tuesdays - 6PM & Saturdays - 11AM



## CITY OF TEXARKANA, AR BOARD OF DIRECTORS

---

**AGENDA TITLE:** Approval of the minutes of the special called meeting at 12:00 PM on April 27, 2023, the regular meeting at 6:00 PM on May 1, 2023 and the special called meeting at 5:00 PM on May 8, 2023. (CCD) City Clerk Heather Soyars

**AGENDA DATE:** May 15, 2023

**ITEM TYPE:** Ordinance  Resolution  Other : Minutes

**DEPARTMENT:** City Clerk Department

**PREPARED BY:** Heather Soyars, City Clerk

---

**REQUEST:** Approval of meeting minutes.

**EMERGENCY CLAUSE:** N/A

---

**SUMMARY:** Approval of meeting minutes

---

**EXPENSE REQUIRED:** N/A

---

**AMOUNT BUDGETED:** N/A

---

**APPROPRIATION REQUIRED:** N/A

---

**RECOMMENDED ACTION:** The City Clerk recommends Board approval.

---

**EXHIBITS:** Meeting minutes.



## **Special Called Meeting of the Board of Directors**

City of Texarkana, Arkansas  
216 Walnut Street

**Minutes - Thursday, April 27, 2023 - 12:00 PM**

Mayor Allen Brown called the meeting to order at 12:00 PM.

**PRESENT:** Mayor Allen Brown, Assistant Mayor Ward 1 Terry Roberts, Ward 2 Director Laney Harris, Ward 4 Director Ulysses Brewer and Ward 5 Director Danny Jewell.

**ABSENT:** Ward 3 Director Steven Hollibush and Ward 6 Jeff Hart.

### **EXECUTIVE SESSION**

The Board of Directors entered Executive Session at 12:05 PM, to interview potential candidates for the City Manager position.

The Mayor reconvened the meeting at 1:04 PM, and no action was taken.

### **ADJOURN**

Motion to adjourn made by Assistant Mayor Roberts, Seconded by Director Brewer.

Voting Yea: Mayor Brown, Assistant Mayor Roberts, Director Harris, Director Brewer, and Director Jewell.

The motion carried 5-0 and the meeting adjourned at 1:05 PM.

**APPROVED** this the 15<sup>th</sup> day of May 2023.

---

Allen L. Brown, Mayor

---

Heather Soyars, City Clerk



## **Regular Meeting of the Board of Directors**

City of Texarkana, Arkansas

216 Walnut Street

**Minutes - Monday, May 01, 2023 - 6:00 PM**

Mayor Allen Brown called the meeting to order at 6:00 PM.

PRESENT: Mayor Allen Brown, Assistant Mayor Ward 1 Terry Roberts, Ward 2 Director Laney Harris, Ward 3 Director Steven Hollibush, Ward 4 Director Ulysses Brewer, and Ward 5 Director Danny Jewell.

ALSO PRESENT: Acting City Manager TyRhonda Henderson, City Attorney Joshua Potter, City Clerk Heather Soyars, and Deputy City Clerk Jenny Narens.

ABSENT: Ward 6 Director Jeff Hart.

Invocation and Pledge of Allegiance given by Assistant Mayor Terry Roberts.

### **CITIZEN COMMUNICATION**

The following persons spoke in support of a petition to the Arkansas Highway Department (ARDOT) to name the Highway 71S viaduct the *Reverend Londell Williams Overpass*.

- Joe Denmon, 10205 Highway 296.
- Bertha Dunn, 2704 East 15<sup>th</sup> Street.
- James Andrew Keeton, 6217 West 7<sup>th</sup> Street.
- Kenneth Reid.
- Larry Jordon, 1615 Delaware.
- Dennis Taylor, Assistant Pastor of Park Avenue Baptist Church.
- Londell Williams, daughter of the late Londell Williams.
- Doris Block.

### **PRESENTATION(S)**

1. Proclamation presented to Danny Gordon for National Preservation Month. (PWD-Planning) City Planner Mary Beck
2. Proclamation presented to City Clerk Heather Soyars for Municipal Clerks Appreciation Week. (CCD) City Clerk Heather Soyars
3. Proclamation presented to Texarkana Water Utilities Executive Director Gary Smith for National Drinking Water Week. (TWU) Executive Director Gary Smith

## CONSENT

Director Brewer made the motion to adopt the Consent agenda, Seconded by Assistant Mayor Roberts. The motion carried and the following items were approved:

4. Approved the minutes of the special called meeting at 4:30 PM on April 17, 2023, and the regular meeting at 6:00 PM on April 17, 2023. (CCD) City Clerk Heather Soyars
5. Resolution No. 2023-34 authorized the Acting City Manager to enter into a construction contract with Phase 1 Concrete, Inc., for the purpose of building an Americans with Disabilities Act (ADA) handicap ramp at the front North of the Bi-State Justice Center. (Bi-State) Bi-State Building Maintenance Manager Kristine Barron
6. Resolution No. 2023-35 authorized the Acting City Manager to enter into a contract with ACS Playground Adventures for the construction and installation of playground equipment at Iron Mountain Park. (PRD) Parks and Recreation Director Adam Dalby

## REGULAR

7. Resolution No. 2023-36 supported a petition to the Arkansas Highway Department (ARDOT) to name the Highway 71S viaduct the *Reverend Londell Williams Overpass*. (PWD-Planning) City Planner Mary Beck

After a brief discussion, the motion to adopt the resolution made by Director Brewer, Seconded by Assistant Mayor Roberts.

Voting Yea: Mayor Brown, Assistant Mayor Roberts, Director Hollibush, Director Brewer, and Director Jewell.

Voting Nay: Director Harris.

The motion carried 5-1 and the Mayor declared the resolution adopted.

8. Ordinance No. 17-2023 rezoned a tract of land located in the 6200 block of Thomasville Lane, from R-1 Rural residential to R-3 Low density residential in order to build a single-family dwelling. (Ward 6) (PWD-Planning) City Planner Mary Beck

After a brief discussion, the motion to suspend the rules and place the ordinance on its first reading in abbreviated form made by Assistant Mayor Roberts, Seconded by Director Hollibush.

Voting Yea: Mayor Brown, Assistant Mayor Roberts, Director Harris, Director Hollibush, Director Brewer, and Director Jewell.

The motion carried 6-0 and the ordinance was read the first time in abbreviated form.

Motion to suspend the rules and place the ordinance on its second reading in abbreviated form made by Director Brewer, Seconded by Director Hollibush.

Voting Yea: Mayor Brown, Assistant Mayor Roberts, Director Harris, Director Hollibush, Director Brewer, and Director Jewell.

The motion carried 6-0 and the ordinance was read the second time in abbreviated form.

Motion to suspend the rules and place the ordinance on its third and final reading in abbreviated form made by Director Hollibush, Seconded by Assistant Mayor Roberts.

Voting Yea: Mayor Brown, Assistant Mayor Roberts, Director Harris, Director Hollibush, Director Brewer, and Director Jewell.

The motion carried 6-0 and the ordinance was read the third time in abbreviated form.

Motion to adopt the ordinance made by Director Hollibush, Seconded by Director Brewer.

Mayor Brown asked if anyone would like to speak for or against this ordinance.

No one came forward.

Voting Yea: Mayor Brown, Assistant Mayor Roberts, Director Harris, Director Hollibush, Director Brewer, and Director Jewell.

The motion carried 6-0 and the Mayor declared the ordinance adopted.

### **BOARD OF DIRECTORS' COMMENTARY**

Director Harris asked if the grass and dirt on the sidewalks in College Hill could be removed before the street sweeper was used on the streets again.

Director Jewel asked if there were any restrictions on the parking lot located on Arkansas Boulevard for the Nix Trail.

**NEXT MEETING DATE: Monday, May 15, 2023**

### **EXECUTIVE SESSION**

The Board of Directors entered Executive Session at 7:10PM.

The Mayor reconvened the meeting at 7:22 PM.

The Board of Directors requested Agenda Item 9. Adopt a Resolution making appointments to various board and commissions. (CCD) City Clerk Heather Soyars, be separated into three resolutions for each board and commission and acted upon by the Board of Directors individually.

~~9. Adopt a Resolution making appointments to various boards and commissions. (CCD) City Clerk Heather Soyars~~

### **ADDENDUM – EXECUTIVE SESSION**

9. **TABLED** - Adopt a Resolution making appointments to the Advertising and Promotion Commission. (CCD) City Clerk Heather Soyars

10. Resolution No. 2023-37 made the following appointments to the Airport Authority. (CCD) City Clerk Heather Soyars

Ronald Bruce Term: 5/14/2023----2026

Adger Smith Term: 5/14/2023----2026



The motion to adopt the resolution made by Director Brewer, Seconded by Director Harris.

Voting Yea: Assistant Mayor Roberts, Director Harris, Director Hollibush, Director Brewer, and Director Jewell.

Voting Nay: Mayor Brown.

The motion carried 5-1 and the Mayor declared the resolution adopted.

11. Resolution No. 2023-38 made the following appointments to the Planning Commission. (CCD)  
City Clerk Heather Soyars

Bertha Dunn                      Term: 5/6/2023----2026

Clyde “Boots” Thomas      Term: 5/6/2023----2026

The motion to adopt the resolution made by Director Hollibush, Seconded by Assistant Mayor Roberts.

Voting Yea: Mayor Brown, Assistant Mayor Roberts, Director Hollibush, Director Brewer, and Director Jewell.

Voting Nay: Director Harris.

The motion carried 5-1 and the Mayor declared the resolution adopted.

**ADJOURN**

Motion to adjourn made by Director Hollibush, Seconded by Assistant Mayor Roberts.

Voting Yea: Mayor Brown, Assistant Mayor Roberts, Director Harris, Director Hollibush, Director Brewer, and Director Jewell.

The motion carried 6-0 and the meeting adjourned at 7:25 PM.

**APPROVED** this the 15<sup>th</sup> day of May 2023.

---

Allen L. Brown, Mayor

---

Heather Soyars, City Clerk



## **Special Called Meeting of the Board of Directors**

City of Texarkana, Arkansas  
216 Walnut Street

**Minutes - Monday, May 8, 2023 - 5:00 PM**

Assistant Mayor Terry Roberts called the meeting to order at 5:00 PM.

**PRESENT:** Assistant Mayor Ward 1 Terry Roberts, Ward 3 Director Steven Hollibush, Ward 5 Director Danny Jewell and Ward 6 Jeff Hart.

**ABSENT:** Mayor Allen Brown, Ward 2 Director Laney Harris, and Ward 4 Director Ulysses Brewer.

### **EXECUTIVE SESSION**

The Board of Directors entered Executive Session at 5:01 PM, to discuss potential candidates for the City Manager position.

The Assistant Mayor reconvened the meeting at 5:40 PM, and no action was taken.

### **ADJOURN**

Motion to adjourn made by Director Hart, Seconded by Director Hollibush.

Voting Yea: Assistant Mayor Ward 1 Terry Roberts, Ward 3 Director Steven Hollibush, Ward 5 Director Danny Jewell and Ward 6 Jeff Hart.

The motion carried 4-0 and the meeting adjourned at 5:41 PM.

**APPROVED** this the 15<sup>th</sup> day of May 2023.

---

Allen L. Brown, Mayor

---

Heather Soyars, City Clerk



## CITY OF TEXARKANA, AR BOARD OF DIRECTORS

---

**AGENDA TITLE:** Adopt a Resolution approving the reimbursement of \$10,335.33 to the Texarkana Regional Airport from American Rescue Act Funds. (FIN)  
Acting City Manager/Finance Director TyRhonda Henderson

**AGENDA DATE:** May 15, 2023

**ITEM TYPE:** Ordinance  Resolution  Other : \_\_\_\_\_

**DEPARTMENT:** Finance Department

**PREPARED BY:** TyRhonda Henderson, Acting City Manager/Finance Director

---

**REQUEST:** N/A

**EMERGENCY CLAUSE:** N/A

---

**SUMMARY:** The American Rescue Act Fund was approved by the City of Texarkana, Arkansas Board of Directors on December 20, 2021, with resolution 2021-65. This budget allocated \$972,090 in 2021 and the remaining \$656,637 in 2022. Of the total \$1,628,727, \$312,927 has been spent. The purpose of this agenda item is to approve the reimbursement of \$10,335.33 to the Texarkana Regional Airport for engineering services in connection with the Landside Development. As this would be considered a general governmental service, it is eligible for reimbursement due to the City receiving less than \$10 million from the American Rescue Plan Act.

---

**EXPENSE REQUIRED:** \$10,335.33

---

**AMOUNT BUDGETED:** \$10,335.33

---

**APPROPRIATION  
REQUIRED:** \$0

---

**RECOMMENDED  
ACTION:** Acting City Manager and staff recommend approval

---

**EXHIBITS:** Resolution and invoice

**RESOLUTION NO. \_\_\_\_\_**

**WHEREAS**, allocated American Rescue Plan Act (ARPA) Funds remain available for use in accordance with applicable law and restriction; and

**WHEREAS**, of the total ARPA funds allocated, \$1,628,727.00, the total spent to date is \$312,927.00; and

**WHEREAS**, an eligible use of a portion of such funds is to reimburse the Airport Authority for \$10,335.33 incurred in connection with Landside Development; and

**WHEREAS**, the Acting City Manager and staff recommend approval;

**NOW, THEREFORE, BE IT RESOLVED**, by the Board of Directors of the City of Texarkana, Arkansas, that the reimbursement described herein is approved and, further, all applicable City budgets are appropriately amended.

**PASSED AND APPROVED** this 15<sup>th</sup> day of May, 2023.

\_\_\_\_\_  
Allen L. Brown, Mayor

**ATTEST:**

\_\_\_\_\_  
Heather Soyars, City Clerk

**APPROVED:**

\_\_\_\_\_  
Joshua L. Potter, City Attorney



Please remit payment to: 7302 Kanis Road | Little Rock, AR 72204  
 For account information contact: Little Rock: 501.371.0272  
 Fayetteville: 479.443.2377  
 Fort Smith: 479.434.5333

Texarkana Regional Airport Authority  
 Paul Mehrlich, Executive Director of Aviation  
 201 Airport Drive  
 Texarkana, AR 71854

Invoice number 225712-013  
 Date 04/10/2023

Project **225712 Texarkana Regional Airport  
 Landside Development - Design Only**

Billing Period: March 1, 2023 through March 31, 2023

Engineering services in connection with the above referenced project in accordance with our agreement and Work order #3.

	Amount	
<b>PRELIMINARY DESIGN &amp; REPORTS</b>		
Contract Amount	28,750.00	
Percent Complete	90.43	
Prior Billed	26,000.00	
Total Billed	26,000.00	
		Current Billed 0.00
<b>GRANT ADMINISTRATION</b>		
Contract Amount	7,500.00	
Percent Complete	29.33	
Prior Billed	2,200.00	
Total Billed	2,200.00	
		Current Billed 0.00
<b>TOPOGRAPHIC SURVEY</b>		
Contract Amount	24,500.00	
Percent Complete	100.00	
Prior Billed	24,500.00	
Total Billed	24,500.00	
		Current Billed 0.00
<b>ENVIRONMENTAL COORDINATION</b>		
Contract Amount	12,500.00	
Percent Complete	100.00	
Prior Billed	10,600.00	
Total Billed	12,500.00	
		Current Billed 1,900.00
<b>GEOTECHNICAL INVESTIGATION</b>		
Contract Amount	20,275.00	
Percent Complete	100.00	
Prior Billed	20,275.00	
Total Billed	20,275.00	
		Current Billed 0.00

Amount

**ENGINEERING DESIGN DOCUMENTS**

Contract Amount	263,975.00
Percent Complete	90.08
Prior Billed	229,352.00
Total Billed	237,787.33

Current Billed	8,435.33
Total	10,335.33

Invoice total **10,335.33**

**Invoice Summary**

Description	Contract Amount	Prior Billed	Total Billed	Current Billed
PRELIMINARY DESIGN & REPORTS	28,750.00	26,000.00	26,000.00	0.00
GRANT ADMINISTRATION	7,500.00	2,200.00	2,200.00	0.00
TOPOGRAPHIC SURVEY	24,500.00	24,500.00	24,500.00	0.00
ENVIRONMENTAL COORDINATION	12,500.00	10,600.00	12,500.00	1,900.00
GEOTECHNICAL INVESTIGATION	20,275.00	20,275.00	20,275.00	0.00
ENGINEERING DESIGN DOCUMENTS	263,975.00	229,352.00	237,787.33	8,435.33
<b>Total</b>	<b>357,500.00</b>	<b>312,927.00</b>	<b>323,262.33</b>	<b>10,335.33</b>

Approved by:



Matthew R. Vinyard  
 Project Manager, P.E.



# CITY OF TEXARKANA, AR

## BOARD OF DIRECTORS

---

**AGENDA TITLE:** Adopt a Resolution authorizing the Acting City Manager to enter into a contract with Artex Electric for the purchase and installation of poles and LED lighting at Field 1 of the Pondexter Sports Complex. (PARKS)  
Parks and Recreation Director Adam Dalby

**AGENDA DATE:** May 15, 2023

**ITEM TYPE:** Ordinance  Resolution  Other : \_\_\_\_\_

**DEPARTMENT:** Parks and Recreation Department

**PREPARED BY:** Adam Dalby, Parks and Recreation Director

---

**REQUEST:** Adopt a resolution authorizing the Acting City Manager to enter into a contract with Artex Electric for the purchase and installation of poles and LED lighting at Field 1 of the Pondexter Sports Complex.

**EMERGENCY CLAUSE:** N/A

---

**SUMMARY:** A resolution authorizing the Acting City Manager to enter into a contract with Artex Electric for the purchase and installation of poles and LED lighting at Field 1 of the Pondexter Sports Complex in the amount of one hundred twenty-six thousand eight hundred and fifty dollars and no cents (\$126,850).

The City solicited bids on January 29<sup>th</sup> and February 5<sup>th</sup>, 2023.

One bid was received as listed below:

Artex Electric      \$126,850

Authorization of this purchase meets all bidding requirements. Funds were budgeted and are available for this purchase.

---

**EXPENSE REQUIRED:** \$126,850

---

**AMOUNT BUDGETED:** \$126,850 (\$142,000 from Advertising and Promotion Commission, approved October 20, 2021, and reallocated January 18, 2023)

---

**APPROPRIATION  
REQUIRED:** \$0.00

---

**RECOMMENDED  
ACTION:** Acting City Manager and staff recommend Board approval.

---

**EXHIBITS:** Resolution, Bid Ad and Bid Tab

**RESOLUTION NO. \_\_\_\_\_**

**WHEREAS**, after advertisement a low bid in the amount of \$126,850.00 was submitted by Artex Electric for the purchase and installation of poles and LED lighting at Field 1 of the Pondexter Sports Complex; and

**WHEREAS**, funds for the purchase and installation of poles and LED lighting were budgeted and are available, with \$142,000.00 from the Advertising and Promotion Commission; and

**WHEREAS**, the Acting City Manager and staff recommend approval;

**NOW, THEREFORE, BE IT RESOLVED**, by the Board of Directors of the City of Texarkana, Arkansas, that the Acting City Manager is authorized to enter into a contract with Artex Electric for the purposes and in the amount set forth above.

**PASSED AND APPROVED** this 15<sup>th</sup> day of May, 2023.

\_\_\_\_\_  
Allen L. Brown, Mayor

**ATTEST:**

\_\_\_\_\_  
Heather Soyars, City Clerk

**APPROVED:**

\_\_\_\_\_  
Joshua L. Potter, City Attorney



## ARK-Finley, Jamie

---

**From:** ARK-Dalby, Adam  
**Sent:** Wednesday, May 3, 2023 9:41 AM  
**To:** ARK-Finley, Jamie  
**Subject:** FW: Advertisement for bid

Adam Dalby  
Director of Parks and Recreation  
216 Walnut Street / P.O. Box 2711  
City of Texarkana, AR 71854  
Phone: 870-779-4943  
Fax: 870-773-2395



---

**From:** ARK-Dalby, Adam  
**Sent:** Wednesday, January 25, 2023 1:56 PM  
**To:** ARK-Reynolds, Melissa <melissa.reynolds@txkusa.org>  
**Subject:** Advertisement for bid

Melissa,

Please send to the gazette to run this Sunday 1/29/2023 and next Sunday 2/5/2023 please.

### ADVERTISEMENT FOR BIDS

Formal Bids will be received at the Office of Parks and Recreation Director, Texarkana Recreation Center, 1 Legion Street, City of Texarkana, Arkansas 71854 until 11:00 AM on February 24, 2023, for the purchase and installation of Poles and LED lighting on Field 1 at Pondexter Sports Complex, 1000 Dudley St. Texarkana Arkansas 71854.

Bid Documents and Specifications may be obtained from the Office of the Parks and Recreation Director, Texarkana Recreation Center, 1 Legion Street, Texarkana, Arkansas 71854 immediately. For more information, please call 870-779-4943 or email [adam.dalby@txkusa.org](mailto:adam.dalby@txkusa.org).

Adam Dalby  
Director of Parks and Recreation  
216 Walnut Street / P.O. Box 2711  
City of Texarkana, AR 71854

41128

Date Thursday, January 26, 2023

11:36 AM

Arkansas Democrat Gazette

Your Sales rep is: Brent Hopkins 870-330-7608

My Fax # is:

Acct: G1255249 Name: \*CITY OF TEXARKANA, A

Phone: 870-779-4944 Address: 216 WALNUT ST

Fax: 234-0-52090-50502

Reply: City: TEXARKANA

State: AR Zip: 71854

Paytype: BL Source: EM TFN:

Rate: L1 Class: 4190 Legal Notices

Days: 2 Rate Issues: 2 Start: Sun, Jan 29, 2023

Stop: Sun, Feb 05, 2023

Editions: TXG/

Underline Woi	0.00	Words:	92	Price:	65.56
Bold Charge	0.00	Lines:	22	Discount:	0.00
Other charge	0.00	Depth:	1.97	Commission:	0.00
Other charge	0.00	Columns:	1	Net Price:	0.00
Other charge	0.00	Graphics:	0	Tax:	0.00
		St Words:	1		
		<input type="checkbox"/> Boxed Ad			
		Total:	65.56		
		Applied Credit:	0.00		

Copline: ADVERTISEMENTFORBIDSFOR

On Hold:

Product Code:

Sort String:

PO #:

Tear Sheets:

**ADVERTISEMENT FOR BIDS**

Formal Bids will be received at the Office of Parks and Recreation Director, Texarkana Recreation Center, 1 Legion Street, City of Texarkana, Arkansas 71854 until 11:00 AM on February 24, 2023, for the purchase and installation of Poles and LED lighting on Field 1 at Pondexter Sports Complex, 1000 Dudley St. Texarkana Arkansas 71854.

Bid Documents and Specifications may be obtained from the Office of the Parks and Recreation Director, Texarkana Recreation Center, 1 Legion Street, Texarkana, Arkansas 71854 immediately. For more information, please call 870-779-4943 or email [adam.dalby@tkusa.org](mailto:adam.dalby@tkusa.org).

Ad shown is not actual print size

Adid: 75647592

**4190 Legal Notices**  
**Education (CLE) classes at the city's expense to keep abreast of legal matters.**  
**III. Types of Legal Service Sought**  
 There are several broad types of legal services required by the City. Individual attorneys or firms shall do all general counsel services listed below.  
 a. Provide legal research, advice, and opinions on a day-to-day basis to elected officials and appointed city officials on all aspects of municipal operations.  
 b. Attend all City Board of Directors' meetings and City Manager Staff meetings serving as City Attorney and providing legal counsel and direction. It will be General Counsel's responsibility to notify the City Prosecutor to provide legal counsel and direction in their absence, as well as notifying the City Manager and City Clerk of their pending absence.  
 c. Develop all Ordinances and Resolutions required for each Board of Directors' meeting.  
 d. Provide all secretarial support, office supplies, and all law books and materials necessary to meet the City's legal needs.  
 e. Conflict of Interest  
 Firms or individual attorneys submitting proposals for legal services should be sensitive to potential conflicts of interest. All potential conflicts must be disclosed.  
 V. Fees for Legal Services  
 Pursuant to §16-11-804, the City shall select the firm or individual

**4190 Legal Notices**  
 attorney best qualified through the evaluation process and negotiate a contract with that firm or individual attorney. Fees are not a consideration until the most qualified firm or individual attorney is selected and negotiations have begun.  
 VI. Proposal Content  
 The following information must be included in the proposal.  
 a. Transmittal letter.  
 b. Name, address, and contact person for the firm or individual attorney.  
 c. Indicate any additional services you may be able to provide as the City's general legal counsel in your proposal.  
 d. Specialized experience and technical competence of firm or individual attorney providing the proposed service. This should include specific, detailed information regarding the attorney actually providing services if the proposal is submitted by a firm. Municipal experience will be considered a plus, and statements should highlight past governmental clients.  
 e. Capacity and capability of the firm or individual attorney to perform the work involved. Specifically, a list of current clients should be provided with a clear explanation of how the City's workload will be balanced against existing clients. The proposal should provide a method to assure the City that critical District Court issues will be handled as a priority.  
 f. Past record of performance of

**4190 Legal Notices**  
 the firm or individual attorney. Your proposal should include names and telephone numbers of any clients who can provide references regarding performance.  
 VII. Evaluation  
 The responsible respondent whose statement is most advantageous to the City will be selected to perform the services. A review committee will analyze each proposal. The weight given to each evaluation factor shall be determined by the review committee.  
 a. Specialized experience and technical competence.  
 b. Previous municipal and governmental experience.  
 c. Capacity and capability to meet City's needs.  
 d. Past Performance.  
 VIII. Questions  
 Questions regarding this Request for Proposals or any related issue may be addressed to:  
 Mayor Allen Brown  
 IX. Request for Proposal Submissions  
 Submissions should be sent to Mayor Allen Brown and received no later than February 28, 2023, by 4:00 PM.  
 Mayor Allen Brown  
 City of Texarkana, Arkansas  
 By mail: P.O. Box 2711  
 Texarkana, Arkansas 75504  
 Hand delivery: 218 Walnut Street  
 Texarkana, Arkansas 71854  
 X. Contract Award  
 It is anticipated the contract will be awarded by April 3, 2023. This publication was paid for by

**4190 Legal Notices**  
 the City of Texarkana, Arkansas, City Clerk Department in the amount of \$953.60  
**REQUEST FOR PROPOSALS RFP#1004-23**  
 Community Healthcare will accept sealed proposals for Electric (RFP #1004-23). Information concerning the specifications and conditions to be met may be obtained by visiting our website at <http://communityhealthcare.com/about-us/contractors/request-for-proposals/>. Proposals will be accepted until 11:00, Tuesday, February 28, 2023. By email: [RFP1004-23@communityhealthcare.com](mailto:RFP1004-23@communityhealthcare.com). Community Healthcare reserves the right to accept or reject in part or in whole any proposals received and waive any formalities, in the best value of Community Healthcare.  
**HOPE PUBLIC SCHOOLS REQUEST FOR YARD MAINTENANCE SERVICE**  
 Hope Public Schools is interested in yard maintenance service for the school district. Property includes the following campuses: Clinton Primary School, 601 Lakeshore Drive Hope High School, 1700 South Main St. Pastory Compound, 921 West Avenue B School Admin Bldg, 117 East 2nd St Beryl Henry Elementary, 2000 South Main St Yarger Middle School, 400 East 6th St Hope Academy of Public Service, 600 West 6th St Edith Brown Campus, 500

**4190 Legal Notices**  
 South Spruce St. Proposals will be valid March 1, 2023 to December 31, 2023. Specifications for services must include at minimum, but not be limited to the following: Mowing and trimming around the buildings, including out, buildings, islands, and fencing. Mowing and trimming along the football stadium and the fields behind and beside the stadium, field house area, and track field. Grass areas around the building to be mowed regularly during the growing season to maintain an average height of 2 1/2" to 3 1/2". Trimming and edging around all landscaping/wood surfaces. "Cappings to be blown off walkways/pavement." Litter and debris to be removed from lawn prior to mowing. Removal of all trash and debris from the property before departure. "Proof of liability insurance is required for one million dollars. Interested persons should submit proposals to the Hope Public Schools Administration Building, 117 East 2nd St, Hope, AR 71801 by February 10, 2023 at 2:00 p.m. Any questions regarding this advertisement, you may contact Steven Slatman, Maintenance Supervisor, at 870-703-7337.  
**REQUEST FOR PROPOSALS RFP#1003-23**  
 Community Healthcare will accept sealed proposals for parking (RFP #1003-23). Information concerning the specifications and conditions to

**4190 Legal Notices**  
 be met may be obtained by visiting our website at <http://communityhealthcare.com/about-us/contractors/request-for-proposals/>. Proposals will be accepted until 11:00, Tuesday, February 28, 2023. By email: [RFP1003-23@communityhealthcare.com](mailto:RFP1003-23@communityhealthcare.com). Community Healthcare reserves the right to accept or reject in part or in whole any proposals received and waive any formalities, in the best value of Community Healthcare.  
**ADVERTISEMENT FOR BIDDING**  
 Formal Bids will be received at the Office of Parks and Recreation Director, Texarkana Recreation Center, 1 Legion Street, City of Texarkana, Arkansas 71854 until 11:00 AM on February 24, 2023, for the purchase and installation of Poles and LED lighting on Field 1 at Ponderosa Complex, 1000 Doffey St. Texarkana Arkansas 71854. Bid Documents and Specifications may be obtained from the Office of the Parks and Recreation Director, Texarkana Recreation Center, 1 Legion Street, Texarkana, Arkansas 71854 im-

**4190 Legal Notices**  
 mediately. For more information, please call 870-770-4949. [www.cityofarizona.com](http://www.cityofarizona.com)  
**ABANDONED 2005 PETERBILT VIN# 1NP030005009861**  
 If not claimed within 45 days the vehicle will be sold, dismantled or destroyed. Vehicles are being held at M & M Wrecker Service 1610 Highway 67 North, Prescott, AR 71857 870-887-4357.  
**NOTICE OF CREDITORS**  
 Notice is hereby given that Letera Administration for the Estate of Melissa Jean Dyer, Deceased, were issued to Randy Moore on the 1st Day of February, 2023, Cause No. 43426 which is pending in the County Court at Law of Bowie County, Texas. All persons having claims against said estate which is being administered are required to present them within the time and manner prescribed by law. Claims may be presented in the care of the Administrator for the estate as follows:  
 Randy Moore  
 P.O. Box 5931  
 Donna Brown

**4190 Legal Notices**  
 Pursuant to Chapter 59, Texas Property Code, Kings Highway Self Storage, which is located at 180 North Kings Hwy, Wake Village, Texas 75501, will hold a public auction of property being sold to satisfy a landlord's lien. The Sale will be held at 9:00 am on Wednesday, February 22, 2023, at Kings Highway Self-Storage, located at 900 North Kings Hwy, Wake Village, Texas 75501. Property will be sold to the highest bidder for CASH ONLY. The seller reserves the right to refuse any bid and to withdraw property from sale for any reason. Property in each space will be sold by the space and immediate removal is required. Property being sold includes miscellaneous contents in the space of the following Tenants:  
 Adam Brown  
 Donna Brown  
 Request for Proposals  
 Website Design, Development, and Support for Texarkana Regional Airport  
 The Texarkana Regional Airport Authority is seeking proposals for the design, development, and support for the Texarkana Regional Airport's main website. View or Download the Request for Proposals Package (RFP) at [www.hfwb.com/it/](http://www.hfwb.com/it/). You may contact airport administration with questions at [admin@hfrairport.com](mailto:admin@hfrairport.com). A mandatory pre-response meeting is scheduled for 2:00 PM CST on February 15, 2023, at 201 Airport Dr. Texarkana, AR 71854 (virtual option available). The submission deadline for this RFP is 5:00 PM CST on February 22, 2023.  
 The Ashdown School District is taking closed bids for the purchase of their high jump and pole vault pit pads and mats. For details, please contact Athletic Director, James Smith at 870-998-3209, or email at [jsmith@ashdownschools.org](mailto:jsmith@ashdownschools.org). All bids must be turned in to the Ashdown School District Administrative Building, 751 Rankle Street, Ashdown, AR 71822, no later than noon on February 13, 2023.  
**NOTICE OF PUBLIC SALE**  
 Pursuant to Chapter 59, Texas Property Code, Kings Highway Self Storage, which is located at 181 South Kings Hwy, Texarkana, Texas 75501, will hold a public auction of property being sold to satisfy a landlord's lien. The Sale will be held at 10:00 am on Wednesday, February 22, 2023, at Kings Highway Self-Storage, located at 181 South Kings Hwy, Texarkana, Texas 75501. Property will be sold to the highest bidder for CASH ONLY. The seller reserves the right to refuse any bid and to withdraw property from sale for any reason. Property in each space will be sold by the space and immediate removal is required. Property being sold includes miscellaneous contents in the space of the following Tenants:  
 Casey Dillard  
 Kristin Delese  
**REQUEST FOR PROPOSALS RFP#1006-23**  
 Community Healthcare will accept sealed proposals for Pest Control (RFP #1006-23). Information concerning the specifications and conditions to be met may be obtained by visiting our website at <http://communityhealthcare.com/about-us/contractors/request-for-proposals/>. Proposals will be accepted until 11:00, Tuesday, February 28, 2023. By email: [RFP1006-23@communityhealthcare.com](mailto:RFP1006-23@communityhealthcare.com). Community Healthcare reserves the right to accept or reject in part or in whole any proposals received and waive any formalities, in the best value of Community Healthcare.

**4190 Legal Notices**  
 (RFP #1006-23). Information concerning the specifications and conditions to be met may be obtained by visiting our website at <http://communityhealthcare.com/about-us/contractors/request-for-proposals/>. Proposals will be accepted until 11:00, Tuesday, February 28, 2023. By email: [RFP1005-23@communityhealthcare.com](mailto:RFP1005-23@communityhealthcare.com). Community Healthcare reserves the right to accept or reject in part or in whole any proposals received and waive any formalities, in the best value of Community Healthcare.  
**MI. Pleasant Independent School District** is requesting bids for several pieces of commercial kitchen equipment. Bid specifications are available at the MI. Pleasant I.S.D. Administration Building, Food Service Department, located at 2230 N. Edwards Ave MI. Pleasant, TX 75455 or online at <http://www.mispd.net/procurement/>.  
 Deadline for Submittal: 2:00 p.m. CST on March 7 at the MI. Pleasant I.S.D. Administration Building located at 2230 N. Edwards Ave, MI. Pleasant, TX 75455. The District will not accept faxed bids.  
 For additional information, please contact Laura Stewart at 903-575-2900.  
 Pleasant I.S.D. reserves the right to accept or reject any or all bids and to accept the bid deemed most advantageous for the district.

**4190 Legal Notices**  
**REQUEST FOR PROPOSALS RFP#1007-23**  
 Community Healthcare will accept sealed proposals for General Contracting (RFP #1007-23). Information concerning the specifications and conditions to be met may be obtained by visiting our website at <http://communityhealthcare.com/about-us/contractors/request-for-proposals/>. Proposals will be accepted until 11:00, Tuesday, February 28, 2023. By email: [RFP1007-23@communityhealthcare.com](mailto:RFP1007-23@communityhealthcare.com). Community Healthcare reserves the right to accept or reject in part or in whole any proposals received and waive any formalities, in the best value of Community Healthcare.

**SHOP OUR CLASSIFIEDS!**

**EMPLOYMENT**

**REAL ESTATE**

**AUTOMOTIVE**

**PETS**

**LIVESTOCK**

**BUY/SELL**

**MUCH MORE!**

**TAG** 870.330.7500  
 101 E. BROAD ST.  
 TEXARKANA, AR 71854  
[WWW.TEXARKANAGAZETTE.COM](http://WWW.TEXARKANAGAZETTE.COM)

**START YOUR CAREER WITH A JOB THAT IS RIGHT FOR YOU!**

“ Fresh out of college, I wasn't sure which job was right for me. Real-Time Job Matching™ helped me identify my best job options & start a bright new career. ”

**Texarkana Gazette**  
 TRY REAL-TIME JOB MATCHING™ & GET HIRED FAST.  
[WWW.TEXARKANAGAZETTE.COM](http://WWW.TEXARKANAGAZETTE.COM)

**Texas Commission on Environmental Quality**



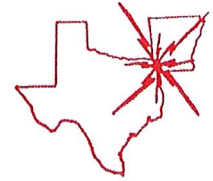

## Proposal

Project: Hobo Jungle Field #1

Date: 4/24/23

To: City of Texarkana Arkansas Parks

Attention: Adam Dalby

From: Nathan

We are pleased to provide pricing for retrofitting existing poles with LED lights. Re-standing 1 existing pole. Providing and installing 1 new 60ft pole. New electrical circuits to all poles. New contactor to control lights. New lights will be 120-277v. Concrete pole bases included. Owner is required to mark all existing water, electric, & sewage lines.

**Base Bid \$ 126,850**

We have seen and included \_ addendums.

Temporary Power and lights are provided and are for walking the job,  
Not for finish work. First bulbs provided.

Exclusions: We do not include in our price- Utility company charges, concrete, concrete or asphalt cutting, or patching, overtime or acceleration cost, trash disposal, patching and painting, roof flashing-boots-pitch pans and surveying.

Our cost is based on toilets being provided on site, on an unmodified AIA Contract, and our Masonry Coordination Procedures.

Since 1967, Artex Electric has served this area with quality work of the highest value. This has made us the largest Electrical Construction and Service Company in this area. For more information- see our web site @ [www.artelectric.com](http://www.artelectric.com).

Thank You Very Much for this Opportunity to Work with You.



# HOSSLEY

LIGHTING AND POWER SOLUTIONS

## POINDEXTER PARK

Quote number #280460

### TEAM

<b>Architect</b>	DESIGN BUILD
<b>Engineer</b>	DESIGN BUILD
<b>Distributor</b>	DEALERS ELECTRIC - TEXARKANA



PREPARED BY

Valorie Fair - Hossley LPS

-

[vfair@hossleylps.com](mailto:vfair@hossleylps.com)

Headquarters, 1202 Dragon St.

Dallas, Texas 75207, USA

# POINDEXTER PARK

Quote number 280460

## Table of Contents

Type	Manufacturer	Model Number	Pg.
		SUBMITTAL APPROVAL DISCLAIMER	1
	WILL BRANDS	VS-RTSA-60-0002-SP-AB-GV-ACR4-VDA / VS-S-ACR-BTP-4-180-GV	2
	WILL BRANDS	WILL BRANDS WARRANTY	8
	EIKO	SIG/600W/750/VD / SIG/Y / SIG-LENS-PC30D / SIG-VISOR-BK	12
	EIKO	SIG/600W/750/VD / SIG-LENS-PC30D / SIG-LENS-PC60D / SIG-VISOR-BK	15
	EIKO	EIKO WARRANTY	18



Project Name: POINDEXTER PARK  
Manufacturer: HLPS  
Model Number: SUBMITTAL APPROVAL DISCLAIMER

Type:

HLPS requires a copy of approved submittals prior to orders being released. If no approved submittals are sent, a waiver will be required stating that the BOM is correct as shown and the distributor accepts all responsibility for the accuracy of the BOM.



Project Name: POINDEXTER PARK  
 Manufacturer: WILL BRANDS  
 Model Number: VS-RTSA-60-0002-SP-AB-GV-ACR4-VDA / VS-S-ACR-BTP-4-180-GV

Type:



Steel

Round Tapered Anchor Base (Sports)

NAFCO® RTSA ROUND TAPERED STEEL ANCHOR BASE SPORT LIGHT POLES

Catalog # \_\_\_\_\_

Project \_\_\_\_\_

Comments \_\_\_\_\_

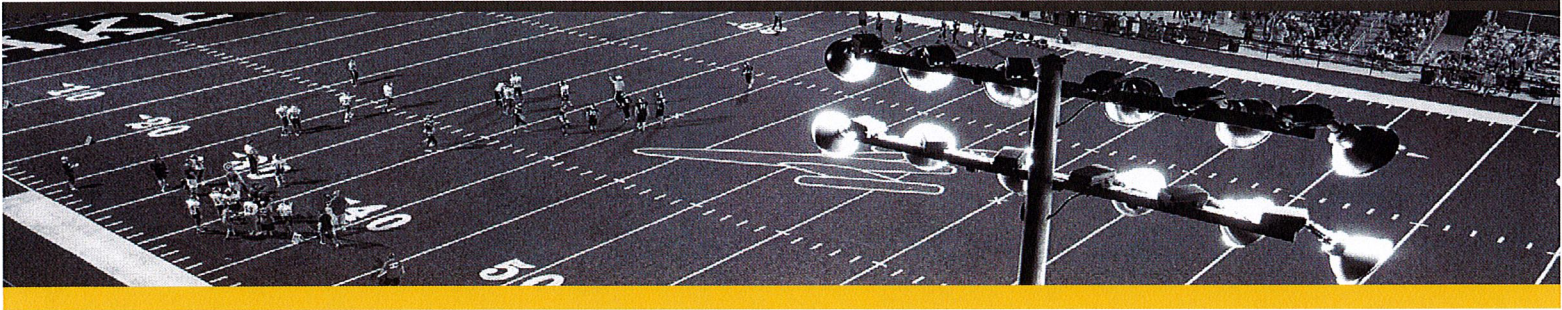

Proudly engineered and manufactured in the American Midwest – our NAFCO® family of professional-grade light pole products combines 50+ years of manufacturing expertise and top-notch Midwestern workmanship. Like all WILL products, NAFCO® poles come supported by our unmatched design, engineering, and project support capabilities.

Specifications

- Pole Shaft** - The pole shaft conforms to ASTM A595 Grade A or A572 Grade 55 with a constant linear taper of 0.14 in/ft. Pole 50' and below are provided as a one-piece unit. Poles greater than 50' are provided as a two-piece field assembled unit.
- Pole Top** - Pole is provided with a removable pole cap.
- Hand Hole** - A reinforced handhole with grounding provision is provided at 3' from the base end of the pole assembly. Each handhole includes a cover and the cover attachment hardware. All pole assemblies are provided with a 4" X 6.5" ovalized handhole. Handhole dimensions are nominal.
- Anchor Bolts** - Anchor bolts conform to ASTM F1554 Grade 55 and are provided with two hex nuts and two flat washers. Bolts have an "L" bend on one end and are galvanized a minimum of 12" on the threaded end.
- Hardware** - All structural fasteners are galvanized high strength carbon steel. All non-structural fasteners are galvanized or zinc-plated carbon steel or stainless steel.
- Finish** - Finishes include galvanized or painted. Please consult factory for special finishing colors and fixture matching options. When storing light poles outside, remove all protective wrapping immediately upon delivery to prevent finish damage.
- Crossarms** - Angle iron and tubular crossarms available in 2,3,4,5 and 6 fixture mounting points. Crossarms bolt directly to light pole.
- Design Criteria** - Please reference Design Criteria Specification for appropriate design conditions.

OPTIONS:

VDA = Internal Vibration Dampener  
 ACR4 = Four Fixture Cross Arm

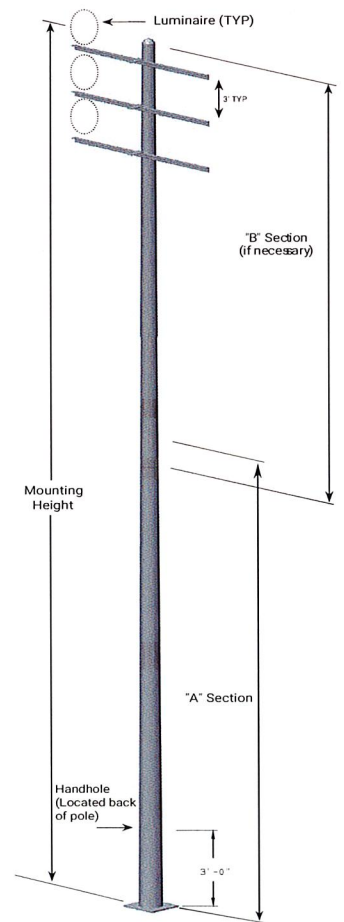

Handhole

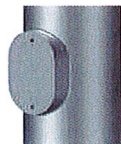

Cross Section

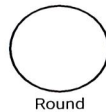

Round

Pole Cap

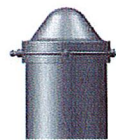

Specifications subject to change without notice.  
 Rev VGBC12022  
 Page 1 of 6

308 N. Brooke St. | Fond du Lac, WI 54935  
 quotes@willbrands.com | www.willbrands.com  
 ©2022







Project Name: POINDEXTER PARK  
 Manufacturer: WILL BRANDS  
 Model Number: VS-RTSA-60-0002-SP-AB-GV-ACR4-VDA / VS-S-ACR-BTP-4-180-GV

Type:



Steel

Round Tapered Anchor Base (Sports)

EPA Loading Guide (Commercial Design Criteria)

Base Model	90mph		100mph		110mph		120mph		130mph		140mph		150mph	
	Max EPA (sq ft)	Max Weight (lb)	Max EPA (sq ft)	Max Weight (lb)	Max EPA (sq ft)	Max Weight (lb)	Max EPA (sq ft)	Max Weight (lb)	Max EPA (sq ft)	Max Weight (lb)	Max EPA (sq ft)	Max Weight (lb)	Max EPA (sq ft)	Max Weight (lb)
VS-RTSA-40-0001-SP-AB-GV	27	675	21.5	538	17.5	438	14.5	363	12	300	10	250	8.5	213
VS-RTSA-40-0002-SP-AB-GV	43	1075	35	875	29	725	24.5	613	20.5	513	17.5	438	15	375
VS-RTSA-50-0001-SP-AB-GV	18.5	463	14.5	363	11	275	9	225	7	175	5.5	138	4.5	113
VS-RTSA-50-0002-SP-AB-GV	24	600	19.5	488	16	400	13.5	338	11.5	288	9.5	238	8.5	213
VS-RTSA-50-0003-SP-AB-GV	33	825	27	675	22.5	563	18.5	463	15.5	388	13	325	11	275
VS-RTSA-50-0004-SP-AB-GV	53	1325	43.5	1088	35.5	888	29.5	738	24.5	613	20.5	513	17	425
VS-RTSA-50-0005-SP-AB-GV	73	1825	60	1500	50	1250	42	1050	35.5	888	30	750	25.5	638
VS-RTSA-55-0001-SP-AB-GV	15.5	388	11.5	288	9	225	7	175	5	125	4	100	3	75
VS-RTSA-55-0002-SP-AB-GV	25.5	638	20.5	513	17	425	14.5	363	12	300	10	250	8.5	213
VS-RTSA-55-0003-SP-AB-GV	44	1100	36	900	30	750	24.5	613	20	500	17	425	14	350
VS-RTSA-55-0004-SP-AB-GV	60	1500	50	1250	42	1050	35.5	888	30	750	25.5	638	21.5	538
VS-RTSA-60-0001-SP-AB-GV	18.5	463	18.5	463	18.5	463	15.5	388	13	325	11	275	9.5	238
VS-RTSA-60-0002-SP-AB-GV	30	750	30	750	27	675	23	575	19.5	488	16.5	413	14	350
VS-RTSA-60-0003-SP-AB-GV	44	1100	44	1100	40.5	1013	34	850	28.5	713	24	600	20	500
VS-RTSA-60-0004-SP-AB-GV	64	1600	64	1600	53	1325	44.5	1113	37.5	938	32	800	27.5	688
VS-RTSA-60-0005-SP-AB-GV	64	1600	64	1600	64	1600	53	1325	44	1100	36.5	913	31	775
VS-RTSA-70-0001-SP-AB-GV	17	425	17	425	15.5	388	12.5	313	11	275	9	225	7.5	188
VS-RTSA-70-0002-SP-AB-GV	22.5	563	21	525	17.5	438	14.5	363	12.5	313	10.5	263	9	225
VS-RTSA-70-0003-SP-AB-GV	33	825	33	825	29	725	24	600	20.5	513	17	425	14.5	363
VS-RTSA-70-0004-SP-AB-GV	49	1225	43.5	1088	36	900	30	750	25	625	21	525	18	450
VS-RTSA-70-0005-SP-AB-GV	58	1450	58	1450	48	1200	40.5	1013	34	850	29	725	24.5	613
VS-RTSA-70-0006-SP-AB-GV	78.5	1963	78.5	1963	67	1675	55.5	1388	47	1175	39.5	988	33.5	838
VS-RTSA-80-0001-SP-AB-GV	25	625	23	575	19.5	488	16	400	13.5	338	11.5	288	9.5	238
VS-RTSA-80-0002-SP-AB-GV	37.5	938	31	775	25.5	638	21.5	538	18	450	15	375	12.5	313
VS-RTSA-80-0003-SP-AB-GV	44.5	1113	40	1000	33	825	27.5	688	23	575	19.5	488	16	400
VS-RTSA-80-0004-SP-AB-GV	61	1525	58.5	1463	48	1200	39.5	988	32.5	813	27	675	22.5	563
VS-RTSA-80-0005-SP-AB-GV	87	2175	80	2000	66.5	1663	55.5	1388	47	1175	40	1000	34	850
VS-RTSA-90-0001-SP-AB-GV	22.5	563	20.5	513	17	425	14	350	12	300	10	250	8.5	213
VS-RTSA-90-0002-SP-AB-GV	34.5	863	28.5	713	23.5	588	20	500	16.5	413	14	350	12	300
VS-RTSA-90-0003-SP-AB-GV	47	1175	47	1175	46.5	1163	38	950	30.5	763	24.5	613	19	475
VS-RTSA-90-0004-SP-AB-GV	69.5	1738	58.5	1463	49	1225	41	1025	34.5	863	29.5	738	25	625
VS-RTSA-90-0005-SP-AB-GV	93	2325	83	2075	68.5	1713	56	1400	47.5	1188	40	1000	34	850
VS-RTSA-100-0001-SP-AB-GV	19.5	488	18.5	463	15	375	12.5	313	10.5	263	9	225	6.5	163
VS-RTSA-100-0002-SP-AB-GV	29.5	738	24.5	613	20	500	17	425	14	350	12	300	10	250
VS-RTSA-100-0003-SP-AB-GV	37	925	34	850	28	750	23.5	588	19.5	488	16	400	13.5	338
VS-RTSA-100-0004-SP-AB-GV	49.5	1238	49.5	1238	43	1075	35.5	888	29	725	23.5	588	18	450
VS-RTSA-100-0005-SP-AB-GV	56	1400	47.5	1188	39.5	988	33.5	838	28	700	24	600	20	500
VS-RTSA-100-0006-SP-AB-GV	76	1900	67.5	1688	55.5	1388	46	1150	38.5	963	32.5	813	27.5	688

Cross Arm Model	EPA
VS-S-ACR-BTP-2-180-GV	1.74
VS-S-ACR-BTP-3-180-GV	2.73
VS-S-ACR-BTP-4-180-GV	3.97
VS-S-ACR-BTP-5-180-GV	5.95
VS-S-ACR-BTP-6-180-GV	7.37

Cross Arm Model	EPA
VS-S-TUB-BTP-2-180-GV	1.28
VS-S-TUB-BTP-3-180-GV	2.45
VS-S-TUB-BTP-4-180-GV	3.21
VS-S-TUB-BTP-5-180-GV	4.17
VS-S-TUB-BTP-6-180-GV	5.13

AASHTO 210 SPECIFICATIONS

The sports lighting structures shown on this drawing have been designed in accordance with the loading and the allowable stress requirements of the 2013 AASHTO standard specifications for structural supports for highway signs, luminaires and traffic signals, sixth edition, LTS-6. The wind loads were calculated from a basic wind velocity of 90 MPH with a recurrence interval of 50 years and a fatigue category of 1. The fatigue loads were calculated on the requirements of section 11 of the code and the following conditions.

- Structures are designed to resist natural wind gusts based on the code requirements in table 11.7.2-1.
- Galloping included cyclic loads are not applicable for sports lighting structures.
- Truck-induced gust loads are not applicable for sports lighting structures.

VIBRATION DISCLAIMER

Although rare, vibration severe enough to cause damage can occasionally occur n structures of all types. Because they are influenced by many variables, vibrations are generally unpredictable. The user's maintenance program should include observation for excessive vibration and examination for any structural damage or bolt loosening. The factory warranty specifically excludes fatigue failure of similar phenomena resulting from induced vibration, harmonic oscillation or resonance associated with movement of air current around the product.

STRUCTURAL NOTICE

Outer section of slip joint connections fabricated from ASTM A572 material will have a complete joint penetration longitudinal seam weld for a minimum distance of 1.5D + 6".

Outer section of slip joint connections fabricated from ASTM A595 material will have the seam weld reinforced with 0.2391" thick x 1.25" wide bars. When measured from the large end, A 4" bar will begin at 0.19" and an 8" bar will begin at 1.5D + 6.18".

Specifications subject to change without notice  
 Rev V08012022  
 Page 2 of 6

308 N. Brooke St. | Fond du Lac, WI 54935  
 quotes@wilbrands.com | www.wilbrands.com  
 ©2022





Project Name: POINDEXTER PARK  
 Manufacturer: WILL BRANDS  
 Model Number: VS-RTSA-60-0002-SP-AB-GV-ACR4-VDA / VS-S-ACR-BTP-4-180-GV

Type:



Steel

Round Tapered Anchor Base (Sports)

Designation & Dimensional Information

Base Model	Pole Dimensions			Base Plate			Anchor Bolts	
	Nominal Mounting Height	Style	Structural Weight (lb)	Bolt Circle Diameter (in)	Center Hole Dia (in)	Sq (in) x Thick (in)	Quantity	Dia x Length x Hook (in)
VS-RTSA-40-0001-SP-AB-GV	40'-0"	1-Piece	552	12.5	9	12.38 x 1.25	4	1.25 x 42 x 6
VS-RTSA-40-0002-SP-AB-GV	40'-0"	1-Piece	651	14	10	14.5 x 1.5	4	1.50 x 54 x 6
VS-RTSA-50-0001-SP-AB-GV	50'-0"	1-Piece	721	13.5	10	14 x 1.25	4	1.25 x 42 x 6
VS-RTSA-50-0002-SP-AB-GV	50'-0"	1-Piece	732	14	10	14.5 x 1.5	4	1.50 x 54 x 6
VS-RTSA-50-0003-SP-AB-GV	50'-0"	1-Piece	852	15	11	16.5 x 1.5	4	1.50 x 54 x 6
VS-RTSA-50-0004-SP-AB-GV	50'-0"	1-Piece	1077	17.5	13	18.5 x 1.75	4	1.75 x 84 x 6
VS-RTSA-50-0005-SP-AB-GV	50'-0"	1-Piece	1378	18	13	18.5 x 2	4	2.00 x 84 x 6
VS-RTSA-55-0001-SP-AB-GV	55'-0"	2-Piece	813	14	10.5	14 x 1.25	4	1.25 x 42 x 6
VS-RTSA-55-0002-SP-AB-GV	55'-0"	2-Piece	904	15	11	16.5 x 1.5	4	1.50 x 54 x 6
VS-RTSA-55-0003-SP-AB-GV	55'-0"	2-Piece	1159	17.5	13	18.5 x 1.75	4	1.75 x 84 x 6
VS-RTSA-55-0004-SP-AB-GV	55'-0"	2-Piece	1431	18	13	18.5 x 2	4	2.00 x 84 x 6
VS-RTSA-60-0001-SP-AB-GV	60'-0"	2-Piece	1115	15.5	10.25	18 x 2	8	1.25 x 42 x 6
VS-RTSA-60-0002-SP-AB-GV	60'-0"	2-Piece	1390	17	9	20 x 2	8	1.50 x 54 x 6
VS-RTSA-60-0003-SP-AB-GV	60'-0"	2-Piece	1696	19	9.25	22 x 2	8	1.50 x 54 x 6
VS-RTSA-60-0004-SP-AB-GV	60'-0"	2-Piece	2083	20.5	10.75	24 x 2.5	8	1.75 x 84 x 6
VS-RTSA-60-0005-SP-AB-GV	60'-0"	2-Piece	2324	20.5	10.75	24 x 2.5	8	1.75 x 84 x 6
VS-RTSA-70-0001-SP-AB-GV	70'-0"	2-Piece	1355	17	10.25	20 x 2	8	1.25 x 42 x 6
VS-RTSA-70-0002-SP-AB-GV	70'-0"	2-Piece	1488	17	9	20 x 2	8	1.50 x 54 x 6
VS-RTSA-70-0003-SP-AB-GV	70'-0"	2-Piece	1836	19	9.25	22 x 2	8	1.50 x 54 x 6
VS-RTSA-70-0004-SP-AB-GV	70'-0"	2-Piece	2224	20.5	10.75	24 x 2.5	8	1.75 x 84 x 6
VS-RTSA-70-0005-SP-AB-GV	70'-0"	2-Piece	2510	21.5	10	26 x 2.25	10	1.75 x 84 x 6
VS-RTSA-70-0006-SP-AB-GV	70'-0"	2-Piece	2951	25	9.5	29.5 x 2.25	10	1.75 x 84 x 6
VS-RTSA-80-0001-SP-AB-GV	80'-0"	2-Piece	1945	19	9.25	22 x 2	8	1.50 x 54 x 6
VS-RTSA-80-0002-SP-AB-GV	80'-0"	2-Piece	2385	20.5	10.75	24 x 2.5	8	1.75 x 84 x 6
VS-RTSA-80-0003-SP-AB-GV	80'-0"	2-Piece	2644	21.5	10	26 x 2.25	10	1.75 x 84 x 6
VS-RTSA-80-0004-SP-AB-GV	80'-0"	2-Piece	3232	25	9.5	29.5 x 2.25	10	1.75 x 84 x 6
VS-RTSA-80-0005-SP-AB-GV	80'-0"	2-Piece	3976	25	9.25	29.5 x 2.75	12	1.75 x 84 x 6
VS-RTSA-90-0001-SP-AB-GV	90'-0"	2-Piece	2320	20.5	10.75	24 x 2.25	8	1.75 x 84 x 6
VS-RTSA-90-0002-SP-AB-GV	90'-0"	2-Piece	2793	21.5	10	25 x 2.25	8	1.75 x 84 x 6
VS-RTSA-90-0003-SP-AB-GV	90'-0"	2-Piece	3618	25	9.5	29.5 x 2.25	10	1.75 x 84 x 6
VS-RTSA-90-0004-SP-AB-GV	90'-0"	2-Piece	4237	25	9.25	29.5 x 2.75	12	1.75 x 84 x 6
VS-RTSA-90-0005-SP-AB-GV	90'-0"	2-Piece	5026	28	9.75	33 x 2.75	10	2.00 x 84 x 6
VS-RTSA-100-0001-SP-AB-GV	100'-0"	2-Piece	2642	21.5	9.75	25 x 2	8	1.75 x 84 x 6
VS-RTSA-100-0002-SP-AB-GV	100'-0"	2-Piece	3179	23	9.75	26.5 x 2.25	8	1.75 x 84 x 6
VS-RTSA-100-0003-SP-AB-GV	100'-0"	2-Piece	3630	25	9.5	29.5 x 2.25	10	1.75 x 84 x 6
VS-RTSA-100-0004-SP-AB-GV	100'-0"	2-Piece	4386	28	10	32.25 x 2.25	12	1.75 x 84 x 6
VS-RTSA-100-0005-SP-AB-GV	100'-0"	2-Piece	4521	25	9.25	29.5 x 2.75	12	1.75 x 84 x 6
VS-RTSA-100-0006-SP-AB-GV	100'-0"	2-Piece	5354	28	9.75	33 x 2.75	10	2.00 x 84 x 6

Cross Arm Model	Length	Weight (lb)
VS-S-ACR-BTP-2-180-GV	3'-6"	30
VS-S-ACR-BTP-3-180-GV	5'-6"	47
VS-S-ACR-BTP-4-180-GV	8'-0"	68
VS-S-ACR-BTP-5-180-GV	10'-6"	103
VS-S-ACR-BTP-6-180-GV	13'-0"	127

Cross Arm Model	Length	Weight (lb)
VS-S-TUB-BTP-2-180-GV	4'-0"	44
VS-S-TUB-BTP-3-180-GV	7'-0"	65
VS-S-TUB-BTP-4-180-GV	10'-0"	98
VS-S-TUB-BTP-5-180-GV	13'-0"	116
VS-S-TUB-BTP-6-180-GV	16'-0"	150

Specifications subject to change without notice  
 Rev. VC8012022  
 Page 3 of 6

308 N. Brooke St. | Fond du Lac, WI 54935  
 quotes@willbrands.com | www.willbrands.com  
 ©2022





Project Name: POINDEXTER PARK  
 Manufacturer: WILL BRANDS  
 Model Number: VS-RTSA-60-0002-SP-AB-GV-ACR4-VDA / VS-S-ACR-BTP-4-180-GV

Type:



Steel

Round Tapered Anchor Base (Sports)

Angle Iron Cross Arms

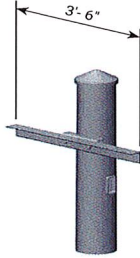

VS-S-ACR-BTP-2-180  
(2 Fixtures)

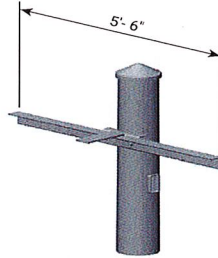

VS-S-ACR-BTP-3-180  
(3 Fixtures)

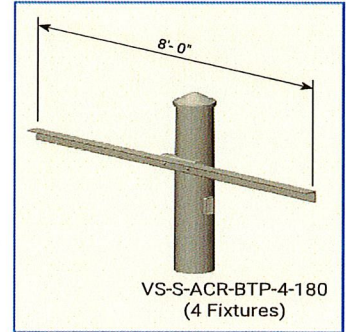

VS-S-ACR-BTP-4-180  
(4 Fixtures)

Note: VS-S-ACR-BT-2-180 Fixture Drillings Spaced 36" on Center  
 All Others: Fixture Drillings Spaced 30" on Center

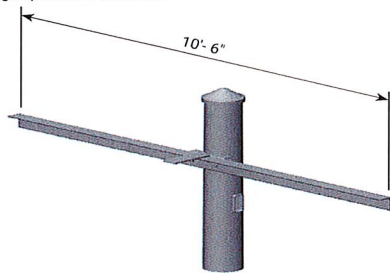

VS-S-ACR-BTP-5-180  
(5 Fixtures)

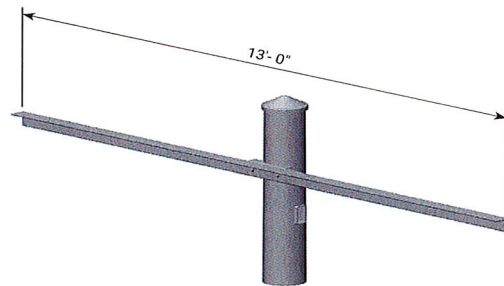

VS-S-ACR-BTP-6-180  
(6 Fixtures)

Tubular Cross Arms

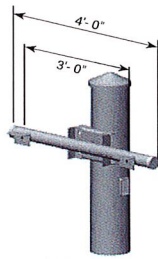

VS-S-TUB-BTP-2-180  
(2 Fixtures)

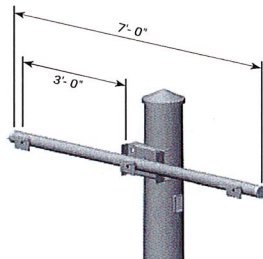

VS-S-TUB-BTP-3-180  
(3 Fixtures)

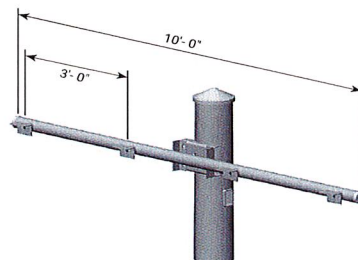

VS-S-TUB-BTP-4-180  
(4 Fixtures)

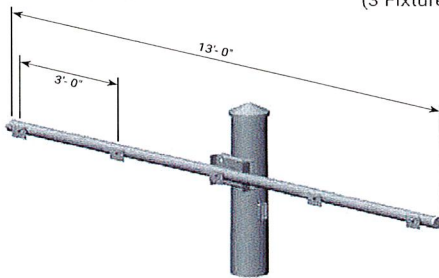

VS-S-TUB-BTP-5-180  
(5 Fixtures)

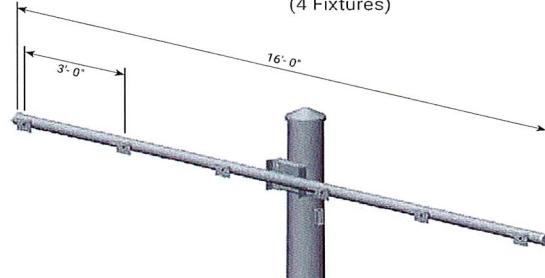

VS-S-TUB-BTP-6-180  
(6 Fixtures)

Specifications subject to change without notice  
 Rev. V08012022  
 Page 4 of 6

308 N. Brooke St. | Fond du Lac, WI 54935  
 quotes@willbrands.com | www.willbrands.com  
 ©2022





Project Name: POINDEXTER PARK  
 Manufacturer: WILL BRANDS  
 Model Number: VS-RTSA-60-0002-SP-AB-GV-ACR4-VDA / VS-S-ACR-BTP-4-180-GV

Type:



Steel

Round Tapered Anchor Base (Sports)

**Cross Arm Mounting Detail**

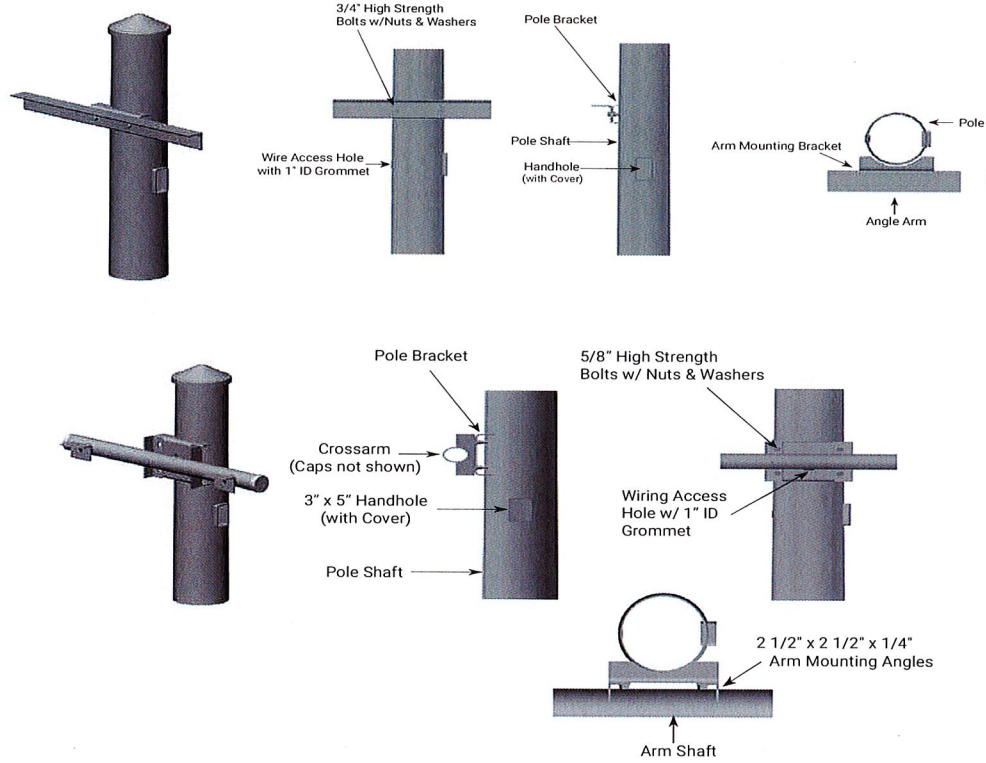

**Base Plate Detail**

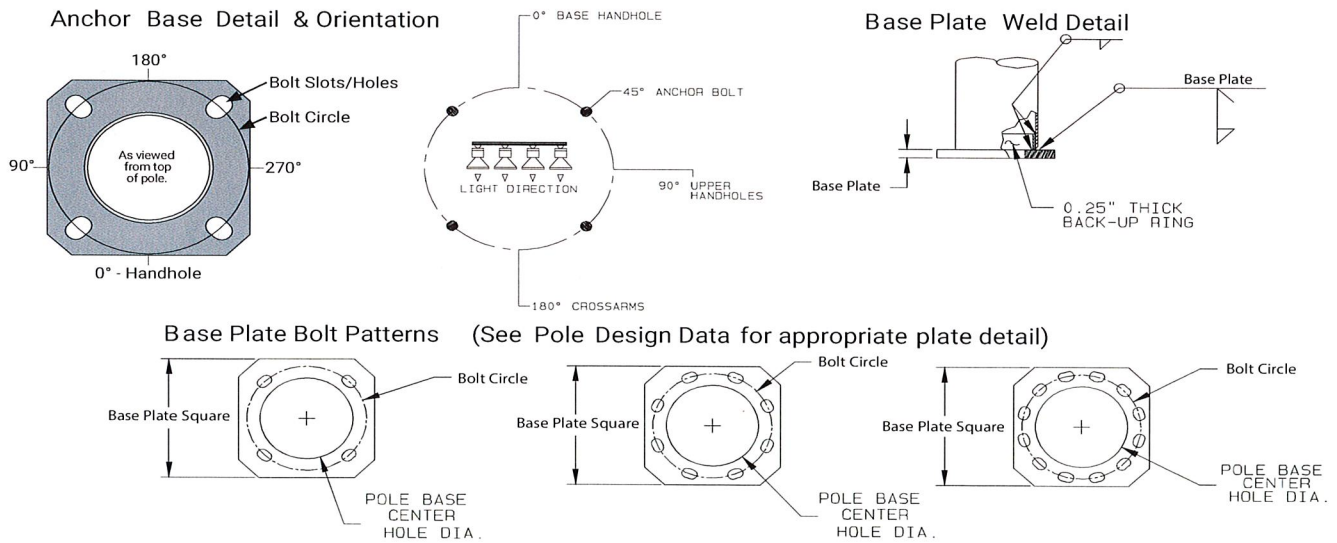

Specifications subject to change without notice  
 Rev. V08012022  
 Page 5 of 6

308 N. Brooke St. | Fond du Lac, WI 54935  
 quotes@willbrands.com | www.willbrands.com  
 ©2022





Project Name: POINDEXTER PARK  
Manufacturer: WILL BRANDS  
Model Number: VS-RTSA-60-0002-SP-AB-GV-ACR4-VDA / VS-S-ACR-BTP-4-180-GV

Type:



Steel

Round Tapered Anchor Base (Sports)

Light Pole Base Reactions

Table with columns for Base Model, 90 MPH (Torsion 0-ft-lbs), 100 MPH (Torsion 0-ft-lbs), 110 MPH (Torsion 0-ft-lbs), 120 MPH (Torsion 0-ft-lbs), 130 MPH (Torsion 0-ft-lbs), 140 MPH (Torsion 0-ft-lbs), 150 MPH (Torsion 0-ft-lbs). Rows list various VS-RTSA-60-0002-SP-AB-GV-ACR4-VDA / VS-S-ACR-BTP-4-180-GV models with associated Bending Moment, Shear Force, and Axial Force values.

Specifications subject to change without notice  
Rev. V08012022  
Page 6 of 6

308 N. Brooke St. | Fond du Lac, WI 54935  
quotes@willbrands.com | www.willbrands.com  
©2022





Project Name: POINDEXTER PARK  
 Manufacturer: WILL BRANDS  
 Model Number: WILL BRANDS WARRANTY

Type:

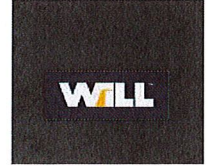

**LIMITED WARRANTY  
 FOR WISCONSIN LIGHTING LAB, INC. LIGHT POLES, BRACKETS, ARMS & LED FIXTURES**

This **LIMITED WARRANTY** is provided to the Buyer by Wisconsin Lighting Lab, Inc. (“WILL”) for the time periods specified in this Agreement. WILL supplied Products will be free of defects in material and workmanship but subject to all of the terms and conditions herein. This shall be the sole and exclusive Limited Warranty given the Buyer or anyone claiming under the Buyer, and WILL disclaims, and the Buyer waives and renounces, all other warranties, express or implied, including, but not limited to, the **WARRANTY OF MERCHANTABILITY** and the **WARRANTY OF FITNESS FOR PURPOSE**, whether such warranties are alleged to have risen from statutes, common law, custom, course of dealing, usage of trade or otherwise. This Limited Warranty only applies to WILL products purchased in new condition in the original WILL supplied packaging.

WILL shall not be liable for any injury, loss, expense or damage, whether direct, consequential, incidental, or otherwise, including, but not limited to, lost production, lost construction time, costs of employees or other losses similar or dissimilar resulting from the possession, installation, erection, start-up, use, maintenance, operation, removal or resale of WILL’s Goods, Products or Services which may be caused by, or alleged to be caused by, any defect or malfunction of any WILL furnished Goods, Products or Services, whether such claim for damage is claimed upon warranty, contract, negligence, or strict liability or otherwise.

The duration of the Limited Warranty begins on the date of shipment of the Goods to the Buyer, or at such location as is directed by Buyer, and expires as follows:

- a. **Standard LED fixture warranty (excludes foundries and select heavy industrial):** On a date five (5) years thereafter as to LED lighting fixtures, including the LED engine and driver, and assuming that the fixture has not been operated the equivalent of more than twelve (12) hours run time per day, 365 days per year.
  - i. A Product shall not be considered defective solely as a result of the failure of individual LED components to emit light if the number of inoperable light emitting diodes in the Product is less than 10% of the total number of light emitting diodes in the Product.
  - ii. This Limited Warranty does not cover any cosmetic Product defects, including without limitation, damage to the painted Product finish or other finish or coating. Nor does this Limited Warranty cover any lumen drop-off or CCT (i.e. color temperature) variations experienced by a Product.
- b. **Extended LED fixture warranty (upon written WILL approval; excludes foundries and select heavy industrial):** On a date ten (10) years thereafter as to LED lighting fixtures, including the LED engine and driver, and assuming that the fixture has not been operated the equivalent of more than twelve (12) hours run time per day, 365 days per year.
  - i. A Product shall not be considered defective solely as a result of the failure of individual LED components to emit light if the number of inoperable light emitting diodes in the Product is less than 15% of the total number of light emitting diodes in the Product.
  - ii. This Limited Warranty does not cover any cosmetic Product defects, including without limitation, damage to the painted Product finish or other finish or coating. Nor does this Limited Warranty cover any lumen drop-off or CCT (i.e. color temperature) variations experienced by a Product.

Rev: 09172020V1

**Wisconsin Lighting Lab, Inc.**  
 206 W. McWilliams St  
 Fond du Lac, WI 54935



Project Name: POINDEXTER PARK  
 Manufacturer: WILL BRANDS  
 Model Number: WILL BRANDS WARRANTY

Type:

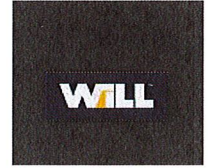

- c. **Extended LED sports lighting warranty (upon written approval):** On a date twenty (20) years thereafter as to LED chip components and ten (10) years thereafter as to LED driver components, and assuming that the fixture has not been operated the equivalent of more than (1500) hours per year.
  - i. A Product shall not be considered defective solely as a result of the failure of individual LED components to emit light if the number of inoperable light emitting diodes in the Product is less than 15% of the total number of light emitting diodes in the Product.
  - ii. This Limited Warranty does not cover any cosmetic Product defects, including without limitation, damage to the painted Product finish or other finish or coating. Nor does this Limited Warranty cover any lumen drop-off or CCT (i.e. color temperature) variations experienced by a Product.
- d. **Standard light pole warranty:** One (1) year as to any light pole, bracket and arm, and any other Goods or Products furnished by WILL.
- e. **3-Year extended light pole warranty (upon written WILL approval):** Three (3) years as to any light pole, bracket and arm, and any other Goods or Products furnished by WILL.
- f. **5-Year extended light pole warranty (upon written WILL approval):** Five (5) years as to any light pole, bracket and arm, and any other Goods or Products furnished by WILL.
- g. This limited warranty covers only those products and components that are manufactured by WILL and does not extend to Third Party Products and Components (regardless of whether they are expressly identified as such). Electronic accessories such as photo controls, motion sensors, backup batteries, surge protectors, etc. are covered by separate OEM supplier warranties. Warranty information for these accessories can be obtained from WILL or the OEM's specification sheet.
- h. Repaired and/or replacement Products are warranted for the remainder of the failed Product's original Warranty Period.
- i. This Limited Warranty is void if customer is in default on any portion of its payment obligations to WILL or to a WILL distributor/dealer.
- j. WILL is not responsible for the labor costs or other expenses associated with Product removal or installation, including, without limitation, shipping costs incurred to return defective or nonconforming Products or any damages that may occur during the return of Products to WILL.

This Limited Warranty will survive and supersede any other documents of the Buyer or others purporting to enlarge or expand the Limited Warranty provided herein by WILL unless the same be acknowledged and agreed to by an authorized representative of WILL in writing. Without limitation, it is specifically agreed that this Limited Warranty excludes any fatigue or failure or similar damage resulting from site induced vibration, harmonic oscillation or resonance associated by movement of air currents around the product or by virtue of natural conditions which do not relate to the Goods, Products or Services supplied by WILL.

The Limited Warranty also excludes any damage caused by negligence; abuse; misuse; mishandling; improper installation, storage or maintenance; installation in an ungrounded system; damage due to fire or acts of God; vandalism; civil disturbances; structural overloading; power surges; lightning strikes; improper power supply; electrical current fluctuations; corrosive environment installations; alteration; accident; failure to follow installation, operating, maintenance or environmental instructions prescribed by WILL or applicable electrical codes; or improper service of the Product performed by someone other than Buyer or its authorized service provider.

Rev: 09172020V1

**Wisconsin Lighting Lab, Inc.**  
 206 W. McWilliams St  
 Fond du Lac, WI 54935



Project Name: POINDEXTER PARK  
 Manufacturer: WILL BRANDS  
 Model Number: WILL BRANDS WARRANTY

Type:



The determination of whether the Product is defective shall be made by WILL in its sole discretion with consideration given to the overall performance of the Product. In the event WILL, in the exercise of its sole discretion, determines that WILL Goods or services furnished by it are defective as to material or workmanship, the sole remedy of the Buyer shall be, at the option of WILL:

- a. Repair of the Goods furnished.
- b. Replacement of the Goods furnished.
- c. Return of the purchase price with WILL reserving the option of salvage as to any remaining value of the Goods which have been furnished by WILL.

WILL reserves the right to utilize new, reconditioned, refurbished, repaired or remanufactured products or parts in the warranty repair or replacement process. Such products and parts will be comparable in function and performance to an original product or part, as determined by WILL in its sole discretion, and the duration of the Limited Warranty is limited to the remainder of the original applicable Limited Warranty.

Cost of return, including shipping, shall be solely Buyer's responsibility.

The Limited Warranty shall be deemed void in the event that, without the written consent of WILL, the Goods or Products furnished by WILL have been modified or in the event any replacement parts or additions to the Goods or Products supplied by WILL have been made by the Buyer or by others without the written consent of WILL.

A condition of any obligation for the above Limited Warranty shall be that the Buyer or anyone claiming under the Buyer observes all of the following:

- a. Terms and Conditions of Sale, which can be found on the following website: [www.nafcointernational.com](http://www.nafcointernational.com)
- b. Installation and Maintenance Guide which can be found on the WILL website at: [www.willbrands.com](http://www.willbrands.com)

By way of example, and not by way of limitation, a small sample of the information contained on WILL's website set forth above are:

- a. Upon receipt, Goods or Products must be carefully inspected and any possible or suspected damage from shipment must be immediately reported to the carrier and to WILL.
- b. Although rare, harmonic vibration results from site conditions that vary by geography. This is unpredictable and may damage light poles or other structural components. The customer should conduct a routine inspection of the base weld and handhole section to identify possible stress cracks and damage from harmonics and loosening of any bolts and hardware on the pole and light fixtures. The WILL Warranty specifically excludes fatigue failure or similar phenomenon resulting from site induced vibration, harmonic oscillation or resonance associated with movement of air current around the Goods or Products.
- c. WILL Goods or Products must be properly removed from their packaging immediately upon receipt by or on behalf of the Buyer to prevent the possibility of any permanent damage to Goods or Products finish and the Goods or Products must be stored in dry conditions prior to their installation in accord with WILL Terms and Conditions of Sale and Installation and Maintenance Guide which can be found at the websites of WILL, including [www.willbrands.com](http://www.willbrands.com).

Rev: 09172020V1

**Wisconsin Lighting Lab, Inc.**  
 206 W. McWilliams St  
 Fond du Lac, WI 54935





Project Name: POINDEXTER PARK  
Manufacturer: WILL BRANDS  
Model Number: WILL BRANDS WARRANTY

Type:

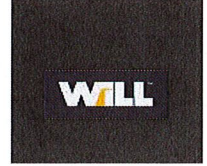

In the event Buyer wishes to receive a direct email or “hard” copy of the WiLL Terms and Conditions of Sale and/or the Installation and Maintenance Guide, please contact the WiLL sales representative with whom the Buyer has dealt.

In order to make a warranty claim, you must notify WiLL in writing within thirty (30) days after your discovery of the defect, provide proof of purchase such as the invoice and comply with Seller's other warranty requirements. Upon receiving that notice, WiLL may require you to promptly return the Product to WiLL, or its authorized service provider, freight prepaid. Your warranty claim should be addressed to Wisconsin Lighting Lab, Inc., 308 North Brooke Street, Fond du Lac, WI 54935.

This warranty is effective for purchases of Product on or after the effective date set forth below. WiLL reserves the right to modify this Limited Warranty from time to time. Any modification of this Limited Warranty shall be effective for all orders placed with Seller on or after the Effective date of such modified or revised Limited Warranty.

**Effective Date: May 1, 2020**

Rev: 09172020V1

**Wisconsin Lighting Lab, Inc.**  
206 W. McWilliams St  
Fond du Lac, WI 54935



Project Name: POINDEXTER PARK  
 Manufacturer: EIKO  
 Model Number: SIG/600W/750/VD / SIG/Y / SIG-LENS-PC30D / SIG-VISOR-BK

Type:



## SIGNAL Flood Light and High Bay

### FEATURES

- Up to 104,000 lumens and 177 lpw efficiency
- Light weight for easy installation
- Multiple distributions available to optimize performance
- Optional visor and reflector help minimize light pollution
- Z10 Receptacle simplifies adding controls
- 20kV surge protection standard

### CERTIFICATIONS

- ETL Listed for wet locations
- IP66 Rated
- 3G rated per ANSI C136.31
- DesignLights Consortium® Premium Qualified

### PERFORMANCE

- Rated lifetime:
  - Projected L70: 100,000 hours
  - Reported L70: >84,000 hours
  - Reported L90: >36,000 hours
- Up to 80,600 lm @ 450W
- Up to 104,500 lm @ 600W
- 4000K, 5000K CCT
- CRI: >70

### ELECTRICAL

- Input voltage: 120-277V, 277-480V
- 0-10V dimming
- Power Factor: >0.9
- THD: <20%
- 10kV driver, plus 20kV supplemental surge protection

### THERMAL

- -40°F to 122 °F (-40°C to 50°C) operating temperature

### CONSTRUCTION

- Cold forged aluminum heatsink ensures optimal performance
- Stainless steel hardware
- Die-cast aluminum driver housing with multiple points of entry for ease of wiring
- Epoxy e-coat primer and durable polyester powder coat ensure maximum protection
- Ships with 3-ft power and dimming cables

### WARRANTY

- 5 year limited warranty. Additional warranty options available. Contact EIKO for details

project name	type
catalog number	voltage
approved by	date



### APPLICATIONS

- Warehouses
- Manufacturing Plants
- Distributions centers
- Hangars
- High Mast
- Bridges, Monuments, Facades
- Rail, Shipping, Work Yards
- Construction Sites
- Outdoor Sports Fields
- Stadiums and Arenas

## CONFIGURATOR

MODEL	LUMEN PACKAGE	CRI/CCT	VOLTAGE	DIMMING
SIG - SIGNAL Flood Light and High Bay	450W - 450W; 80,600 lm 600W - 600W; 104,500 lm	740 - 70 CRI; 4000K 750 - 70 CRI; 5000K	U - 120-277V V - 277-480V	D - 0-10V Dimming



1

©2021 EIKO Global, LLC. World Headquarters: 18000 W. 105<sup>th</sup> Street, Olathe, KS 66061 (P) 1.800.852.2217 (F) 1.800.492.8975  
 EIKO Global Canada, LLC: 81 King Street, Barrie, ON L4N 6B5 Canada (P) 1.888.410.8151 (F) 1.888.705.1335

eiko.com  
 Rev. 12/20/21



Project Name: POINDEXTER PARK  
 Manufacturer: EIKO  
 Model Number: SIG/600W/750/VD / SIG/Y / SIG-LENS-PC30D / SIG-VISOR-BK

Type:

## PERFORMANCE SUMMARY

ORDER CODE	ITEM #	WATTS	NOMINAL LUMENS	LPW	CRI	CCT	DIMMING	VOLTS	DLC PREMIUM
<b>UNIVERSAL VOLTAGE</b>									
12345	SIG/450W/740/UD	450W	76,185	169	>70	4000K	0-10V	120-277V	✓
12346	SIG/450W/750/UD	450W	77,130	171	>70	5000K	0-10V	120-277V	✓
12349	SIG/600W/740/UD	600W	98,750	165	>70	4000K	0-10V	120-277V	✓
12350	SIG/600W/750/UD	600W	99,960	167	>70	5000K	0-10V	120-277V	✓
<b>HIGH VOLTAGE</b>									
12347	SIG/450W/740/VD	450W	79,600	177	>70	4000K	0-10V	277-480V	✓
12348	SIG/450W/750/VD	450W	80,600	179	>70	5000K	0-10V	277-480V	✓
12353	SIG/600W/740/VD	600W	103,200	172	>70	4000K	0-10V	277-480V	✓
12358	SIG/600W/750/VD	600W	104,460	174	>70	5000K	0-10V	277-480V	✓

## ACCESSORIES

ORDER CODE	ITEM #	DESCRIPTION
12359	SIG/AL100D	Signal Reflector 100°
12360	SIG/Y	Signal Yoke Mounting Bracket
12361	SIG/SF	Signal Slipfitter for up to 2 3/8" Pipe
12362	SIG/SM	Signal Surface Mount
10188	SIG-LENS-PC30D	Signal Lens, 30°
10189	SIG-LENS-PC60D	Signal Lens, 60°
10185	SIG-VISOR-BK	Signal Visor, Black
10190	SIG-REFLECTOR-AL90D	Signal Reflector, Aluminum, 90 Degree

## SCALING FACTORS

DISTRIBUTION OPTION	
PC30D	0.97
PC60D	0.98
AL90D	0.95

## EPA AND WEIGHT CHART

MODEL #	ITEM #	DESCRIPTION
SIG/450W/7XX/XD	28.2lbs (12.8kg)	2.09ft <sup>2</sup> (without visor)
SIG/600W/7XX/XD	29.8lb (13.5kg)	
SIG/AL100D	2.20 lbs (1kg)	n/a
SIG/Y	6.5lbs (2.95kg)	n/a
SIG/SF	8.93lb (4.05kg)	n/a
SIG/SM	7.28lb (3.3kg)	n/a
SIG-VISOR-BK	2.76lbs (1.25kg)	2.236ft <sup>2</sup> (fixture with visor)
SIG-REFLECTOR-AL90D	2.87lb (1.3kg)	n/a

## PRODUCT DIMENSIONS

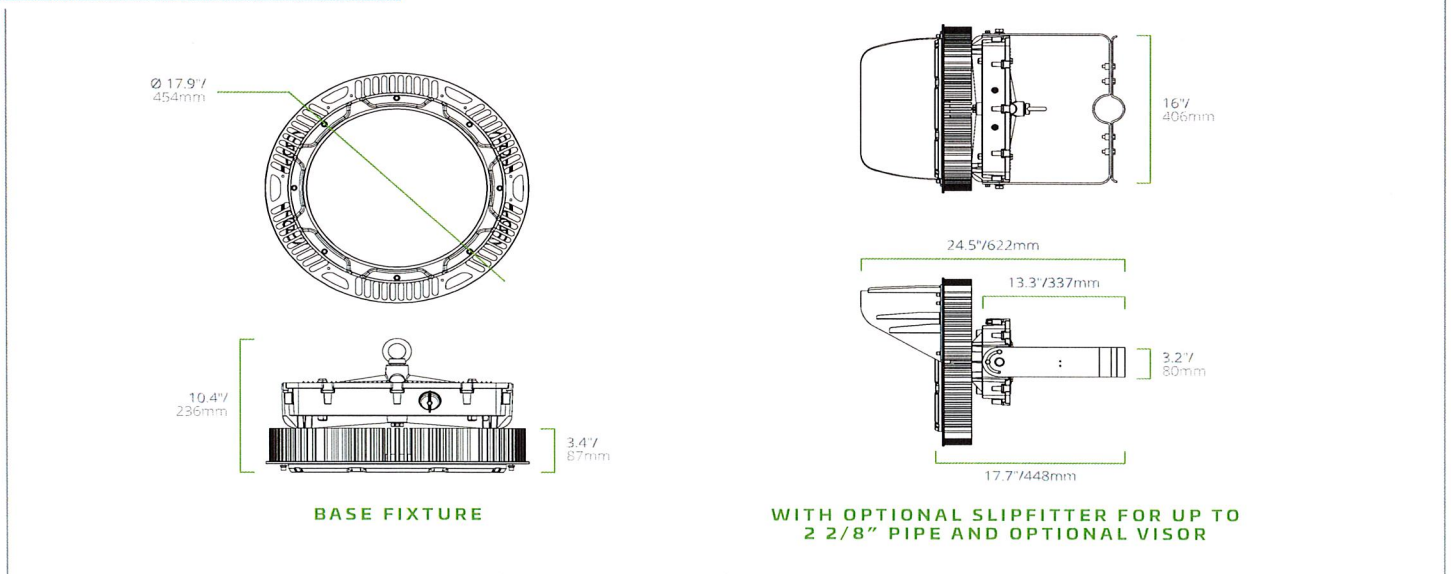



Project Name: POINDEXTER PARK  
 Manufacturer: EIKO  
 Model Number: SIG/600W/750/VD / SIG/Y / SIG-LENS-PC30D / SIG-VISOR-BK

Type:

**PRODUCT DIMENSIONS**

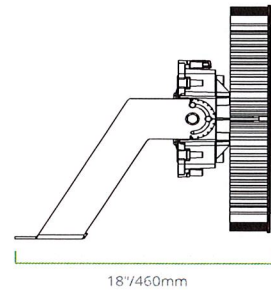
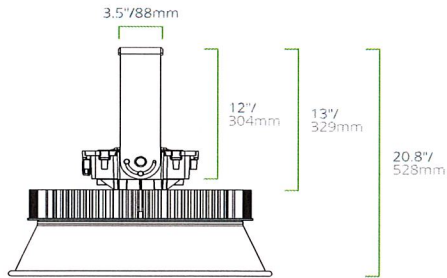
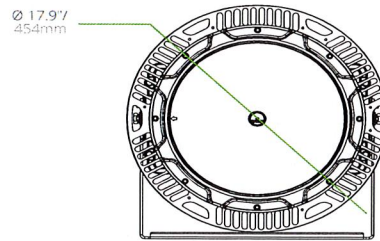
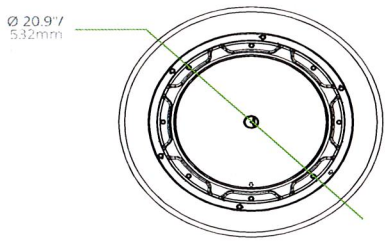

**WITH OPTIONAL SURFACE MOUNT AND  
 OPTIONAL 100° REFLECTOR**

**WITH OPTIONAL YOKE MOUNT**



Project Name: POINDEXTER PARK  
 Manufacturer: EIKO  
 Model Number: SIG/600W/750/VD / SIG-LENS-PC30D / SIG-LENS-PC60D / SIG-VISOR-BK

Type:



## SIGNAL Flood Light and High Bay

### FEATURES

- Up to 104,000 lumens and 177 lpw efficiency
- Light weight for easy installation
- Multiple distributions available to optimize performance
- Optional visor and reflector help minimize light pollution
- Z10 Receptacle simplifies adding controls
- 20kV surge protection standard

### CERTIFICATIONS

- ETL Listed for wet locations
- IP66 Rated
- 3G rated per ANSI C136.31
- DesignLights Consortium® Premium Qualified

### PERFORMANCE

- Rated lifetime:
  - Projected L70: 100,000 hours
  - Reported L70: >84,000 hours
  - Reported L90: >36,000 hours
- Up to 80,600 lm @ 450W
- Up to 104,500 lm @ 600W
- 4000K, 5000K CCT
- CRI: >70

### ELECTRICAL

- Input voltage: 120-277V, 277-480V
- 0-10V dimming
- Power Factor: >0.9
- THD: <20%
- 10kV driver, plus 20kV supplemental surge protection

### THERMAL

- -40°F to 122 °F (-40°C to 50°C) operating temperature

### CONSTRUCTION

- Cold forged aluminum heatsink ensures optimal performance
- Stainless steel hardware
- Die-cast aluminum driver housing with multiple points of entry for ease of wiring
- Epoxy e-coat primer and durable polyester powder coat ensure maximum protection
- Ships with 3-ft power and dimming cables

### WARRANTY

- 5 year limited warranty. Additional warranty options available. Contact EiKO for details

project name	type
catalog number	voltage
approved by	date



### APPLICATIONS

- Warehouses
- Manufacturing Plants
- Distributions centers
- Hangars
- High Mast
- Bridges, Monuments, Facades
- Rail, Shipping, Work Yards
- Construction Sites
- Outdoor Sports Fields
- Stadiums and Arenas

## CONFIGURATOR

MODEL	LUMEN PACKAGE	CRI/CCT	VOLTAGE	DIMMING
SIG - SIGNAL Flood Light and High Bay	450W - 450W; 80,600 lm	740 - 70 CRI; 4000K	U - 120-277V	D - 0-10V Dimming
	600W - 600W; 104,500 lm	750 - 70 CRI; 5000K	V - 277-480V	



1

©2021 EiKO Global, LLC. World Headquarters: 18000 W. 105<sup>th</sup> Street, Olathe, KS 66061 (P) 1.800.852.2217 (F) 1.800.492.8975  
 EiKO Global Canada, LLC: 81 King Street, Barrie, ON L4N 6B5 Canada (P) 1.888.410.8151 (F) 1.888.705.1335

eiko.com  
 Rev. 12/20/21



Project Name: POINDEXTER PARK  
 Manufacturer: EIKO  
 Model Number: SIG/600W/750/VD / SIG-LENS-PC30D / SIG-LENS-PC60D / SIG-VISOR-BK

Type:

## PERFORMANCE SUMMARY

ORDER CODE	ITEM #	WATTS	NOMINAL LUMENS	LPW	CRI	CCT	DIMMING	VOLTS	DLC PREMIUM
<b>UNIVERSAL VOLTAGE</b>									
12345	SIG/450W/740/UD	450W	76,185	169	>70	4000K	0-10V	120-277V	✓
12346	SIG/450W/750/UD	450W	77,130	171	>70	5000K	0-10V	120-277V	✓
12349	SIG/600W/740/UD	600W	98,750	165	>70	4000K	0-10V	120-277V	✓
12350	SIG/600W/750/UD	600W	99,960	167	>70	5000K	0-10V	120-277V	✓

ORDER CODE	ITEM #	WATTS	NOMINAL LUMENS	LPW	CRI	CCT	DIMMING	VOLTS	DLC PREMIUM
<b>HIGH VOLTAGE</b>									
12347	SIG/450W/740/VD	450W	79,600	177	>70	4000K	0-10V	277-480V	✓
12348	SIG/450W/750/VD	450W	80,600	179	>70	5000K	0-10V	277-480V	✓
12353	SIG/600W/740/VD	600W	103,200	172	>70	4000K	0-10V	277-480V	✓
12358	SIG/600W/750/VD	600W	104,460	174	>70	5000K	0-10V	277-480V	✓

## ACCESSORIES

ORDER CODE	ITEM #	DESCRIPTION
12359	SIG/AL100D	Signal Reflector 100°
12360	SIG/Y	Signal Yoke Mounting Bracket
12361	SIG/SF	Signal Slipfitter for up to 2 3/8" Pipe
12362	SIG/SM	Signal Surface Mount
10188	SIG-LENS-PC30D	Signal Lens, 30°
10189	SIG-LENS-PC60D	Signal Lens, 60°
10185	SIG-VISOR-BK	Signal Visor, Black
10190	SIG-REFLECTOR-AL90D	Signal Reflector, Aluminum, 90 Degree

## SCALING FACTORS

DISTRIBUTION OPTION	
PC30D	0.97
PC60D	0.98
AL90D	0.95

## EPA AND WEIGHT CHART

MODEL #	ITEM #	DESCRIPTION
SIG/450W/7XX/XD	28.2lbs (12.8kg)	2.09ft² (without visor)
SIG/600W/7XX/XD	29.8lb (13.5kg)	
SIG/AL100D	2.20 lbs (1kg)	n/a
SIG/Y	6.5lbs (2.95kg)	n/a
SIG/SF	8.93lb (4.05kg)	n/a
SIG/SM	7.28lb (3.3kg)	n/a
SIG-VISOR-BK	2.76lbs (1.25kg)	2.236ft² (fixture with visor)
SIG-REFLECTOR-AL90D	2.87lb (1.3kg)	n/a

## PRODUCT DIMENSIONS

**BASE FIXTURE**

- Ø 17.9" / 454mm
- 10.4" / 236mm
- 3.4" / 87mm

**WITH OPTIONAL SLIPFITTER FOR UP TO 2 2/8" PIPE AND OPTIONAL VISOR**

- 16" / 406mm
- 24.5" / 622mm
- 13.3" / 337mm
- 3.2" / 80mm
- 17.7" / 448mm



Project Name: POINDEXTER PARK  
Manufacturer: EIKO  
Model Number: SIG/600W/750/VD / SIG-LENS-PC30D / SIG-LENS-PC60D / SIG-VISOR-BK

Type:

## PRODUCT DIMENSIONS

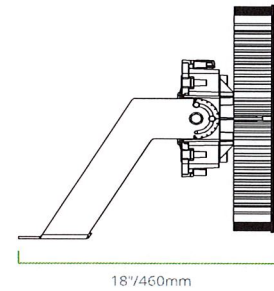
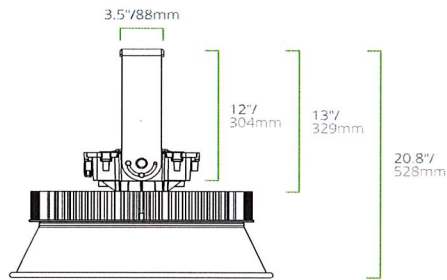
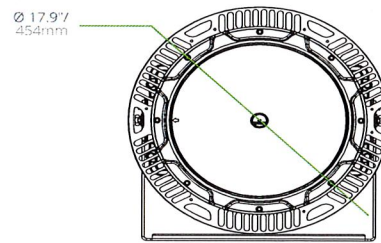
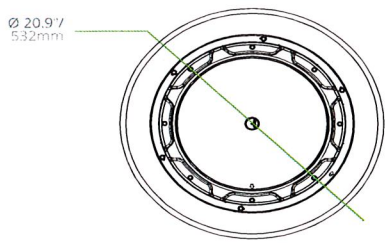

WITH OPTIONAL SURFACE MOUNT AND  
OPTIONAL 100° REFLECTOR

WITH OPTIONAL YOKE MOUNT



Project Name: POINDEXTER PARK  
 Manufacturer: EIKO  
 Model Number: EIKO WARRANTY

Type:



## Limited Warranty for EIKO Global, LLC Products

EIKO Global, LLC ("Seller") warrants that the product sold to you shall be free of defects in material and workmanship for the period listed in the chart below from the date of original purchase order. This limited warranty is provided by the Seller to you as the original purchaser of the Product. The determination of whether the Product is defective shall be made by the Seller, in its sole discretion. A Product shall not be considered defective solely as a result of the failure of individual LEDs. A Product shall be deemed defective when at least 10% of the LEDs in the Product fail to emit light. The painted finish of the Product(s) will be considered defective in material or workmanship only if there is substantial deterioration, in the form of blistering, cracking, or peeling. The painted finish is not warranted against fading or chalking, as Product(s) may naturally fade or chalk over time due to normal aging.

### PRODUCT WARRANTY CHART

PRODUCT GROUP	WARRANTY PERIOD
<b>LED</b>	
LED Fixtures	As per product spec sheet
LED Downlights ≥ 50,000 hours	5 Years
LED Downlights 25,000 to 49,999 hours	3 Years
LED Downlights <25,000 hours	1 Year
LED Lamps ≥ 50,000 hours	5 Years
LED Lamps 25,000 to 49,999 hours	3 Years
LED Lamps <25,000 hours	1 Year
<i>Warranty period for LED Lamps and LED Downlights are based on operation of 12 hours per day, 365 days per year. Warranty applicable for LED Lamps that use an external driver only for use with Eiko branded driver from datasheet. LED Downlights and LED Lamps with Energy Star and a design life &lt;25,000 hours have a warranty period of 3 years based on lamp operation of 3 hours per day, 365 days per year.</i>	
<b>HID</b>	
High Pressure Sodium	3 Years
Quartz Metal Halide (excluding MH1500)	1 Year
<i>Warranty period based on a maximum operation of 4,000 hours per year.</i>	
<b>LINEAR FLUORESCENT</b>	
T5 Lamps	30/36 Months
<i>Warranty period based on 3hr/12hr start times on programmed start ballasts, without use of sensors, and a maximum operation of 5,110 hours per year. T5 Lamps used on programmed start ballasts with sensors (set to 15 minutes minimum on time) - 2 Years. Warranty period based on 3hr/12hr start times on programmed start ballasts and a maximum operation of 5,110 hours per year.</i>	
T8 Lamps	30/30 Months
<i>Warranty period based on 3hr/12hr start times on instant start ballasts, without use of sensors, and a maximum operation of 5,110 hours per year.</i>	
<b>COMPACT FLORESCENT NON-INTEGRATED BALLAST</b>	
PLL	2 Years
PLC	1 Year
<b>COMPACT FLORESCENT INTEGRATED BALLAST</b>	
CFLI	1 Year

*\*All incandescent and halogen lamps are sold as-is with no warranties.*

service. solutions. simplicity. **EIKO.COM** | CUSTOMER SERVICE: **1.800.852.2217**



Revised Dec. 2022





Project Name: POINDEXTER PARK  
 Manufacturer: EIKO  
 Model Number: EIKO WARRANTY

Type:



## WARRANTY CLAIMS

To make a claim, you must contact an EIKO Global, LLC representative within 30 days of the failure. Please retain the failed product for inspection. A copy of your original receipt/invoice will be required.

If, at the determination of the Seller, the Product is deemed defective, the Seller shall, at its own discretion, may elect to satisfy the warranty through any of the following methods: refund the current replacement value, repair the existing Product or replace the Product in question. Warranty value is determined by the included "Warranty Replacement Period Calculations" chart.

In the event of refund, the Seller will refund only the current replacement value of the Product. In the event of repair, the Seller shall reserve the right to use new or refurbished parts. In the event of replacement, the Seller reserves the right to use new or refurbished parts. In the event of replacement, the Seller reserves the right to replace with non-identical Products that are of similar specifications. In the case of repair, replacement or refund, the warranty period shall continue as of the date of the original purchase.

Upon giving warranty notice, and if directed to do so, promptly return the Product - with freight prepaid by EIKO Global, LLC - to the Seller or its authorized service provider. Address warranty claims to:

email: returns@eiko.com  
 phone: [direct] 1-913-667-6307  
 [toll free] 1-800-852-2217 x2  
 US CST - (8:00am - 4:30pm)  
 address: 6825 Orville Ave, Building 3, Suite 401  
 Kansas City, KS 66102

## WARRANTY EXCLUSIONS

This limited warranty applies only when the Product(s) are installed in applications in which ambient temperatures are within the range of specified operating temperatures and are operated within the electrical values noted for the product. Seller will not be responsible under this limited warranty for any failure or loss of the Product(s) that results from external causes such as: negligence; abuse; improper or unauthorized use, installation, handling, storage, maintenance or service, including failure to follow installation, operating, maintenance or environmental instructions prescribed by Seller or applicable national and/or local electrical codes; exposure to adverse or hazardous chemical or other substances; use of reactive cleaning agents and/or harsh chemicals to clean the Product(s); a casualty event; acts of nature; fire; vandalism; civil disturbances; animal or insect activity; power failure; improper power supply; power surges or dips, and/or excessive switching; corrosive environment installations\*; induced vibration; harmonic oscillation or resonance associated with movement of air currents around the Product(s); alteration; accident; or improper service of the Product(s) performed by someone other than Seller or its authorized service provider or any other occurrences beyond the reasonable control of the Seller.

This limited warranty excludes field labor and service charges related to the repair or replacement of the Product. Freight is prepaid by The Seller. THIS LIMITED WARRANTY IS VOID IF THE PRODUCT IS NOT USED FOR THE PURPOSE FOR WHICH IT IS DESIGNED OR IF ANY REPAIRS OR ALTERATIONS ARE MADE BY ANY PERSON NOT AUTHORIZED BY EIKO GLOBAL, LLC IN WRITING.

\*Note models indicated as "NEMA4X" are permitted in corrosive natatorium environments.

## TERMS & CONDITIONS

No distributor, salesperson, dealer, retailer or other representative has the authority to change, modify or extend this warranty in any respect, either verbally or in writing.

The Seller reserves the right to inspect the failed product to determine the cause of failure, and reserves the right to be the sole judge as to whether the product is defective and covered under warranty.

Products sold with installed modifications are final and non-returnable.

## WARRANTY REPLACEMENT PERIOD CALCULATIONS

BASED ON THE DATE OF PURCHASE				
Year 1	Year 2	Year 3	Year 4	Year 5
No charge repair or replacement				
Year 6	Year 7	Year 8	Year 9	Year 10
the lesser of; 50% of price paid as per original invoice, or 50% of equivalent value replacement	the lesser of; 40% of price paid as per original invoice, or 40% of equivalent value replacement	the lesser of; 30% of price paid as per original invoice, or 30% of equivalent value replacement	the lesser of; 20% of price paid as per original invoice, or 20% of equivalent value replacement	the lesser of; 10% of price paid as per original invoice, or 10% of equivalent value replacement

The foregoing warranty provisions are exclusive and are given and accepted in lieu of any and all other warranties. Whether expressed or implied, including without limitation any warranty against infringement and any implied warranties of merchantability or fitness for a particular purpose.

In no event shall the seller be liable for incidental, compensatory, consequential, indirect, special or other damages. Seller's aggregate liability with respect to a defective product shall in any event be limited to monies paid to seller for that defective product.

This warranty is effective for purchases of Product on or after the revised date. Seller reserves the right to modify this warranty and is subject to change without notice. Any modification of this warranty shall be effective for all orders placed with Seller on or after the revised warranty date.

service. solutions. simplicity. **EIKO.COM** | CUSTOMER SERVICE: **1.800.852.2217**



Revised Dec. 2022



# CITY OF TEXARKANA, AR

## BOARD OF DIRECTORS

---

<b>AGENDA TITLE:</b>	Adopt a Resolution authorizing the Acting City Manager to enter into a Purchase Agreement with Ledwell & Son Enterprises, Inc., for a 2,000 Gallon Water Truck. (PWD) Public Works Director Tyler Richards
<b>AGENDA DATE:</b>	May 15, 2023
<b>ITEM TYPE:</b>	Ordinance <input type="checkbox"/> Resolution <input checked="" type="checkbox"/> Other <input type="checkbox"/> : _____
<b>DEPARTMENT:</b>	Public Works Department
<b>PREPARED BY:</b>	Tracie Lee, Assistant Public Works Director

---

<b>REQUEST:</b>	Adopt a resolution authorizing the Acting City Manager to enter into a Purchase Agreement with Ledwell & Son Enterprises, Inc., for a 2,000 Gallon Water Truck.
<b>EMERGENCY CLAUSE:</b>	N/A

---

<b>SUMMARY:</b>	<p>A resolution authorizing the purchase of a 2,000 Gallon Water Truck from Ledwell &amp; Son Enterprises, Inc., in the amount of one hundred eleven thousand two hundred eighty-four dollars and twenty-four cents (\$111,284.24).</p> <p>The City solicited sealed bids on April 23<sup>rd</sup> and 30<sup>th</sup>, 2023 for a 2,000 Gallon Water Truck. Only one bid was received.</p> <p>Authorization of this purchase meets all bidding requirements. Funds were budgeted and are available for the purchase.</p>
-----------------	---

---

<b>EXPENSE REQUIRED:</b>	\$111,284.24
<b>AMOUNT BUDGETED:</b>	\$111,284.24 (Streets Capital Outlay)
<b>APPROPRIATION REQUIRED:</b>	\$0.00

---

<b>RECOMMENDED ACTION:</b>	Acting City Manager and staff recommend board approval.
----------------------------	---

---

<b>EXHIBITS:</b>	Resolution, Bid Ad, and Ledwell & Son Enterprises, Inc., Bid.
------------------	---

---

**RESOLUTION NO. \_\_\_\_\_**

**WHEREAS**, after advertisement a low bid in the amount of \$111,284.24 was submitted by Ledwell & Son Enterprises, Inc., for the purchase a 2,000 Gallon Water Truck; and

**WHEREAS**, funds for the purchase of the Water Truck were budgeted and are available; and

**WHEREAS**, the Acting City Manager and staff recommend approval;

**NOW, THEREFORE, BE IT RESOLVED**, by the Board of Directors of the City of Texarkana, Arkansas, that the Acting City Manager is authorized to enter into a contract with Ledwell & Son Enterprises, Inc., for the purposes and in the amount set forth above.

**PASSED AND APPROVED** this 15<sup>th</sup> day of May, 2023.

\_\_\_\_\_  
Allen L. Brown, Mayor

**ATTEST:**

\_\_\_\_\_  
Heather Soyars, City Clerk

**APPROVED:**

\_\_\_\_\_  
Joshua L. Potter, City Attorney



4180 Legal Notices
Little Rock, AR 72205
501-551-1616
mrobins@stlouispostdispatch.com

PUBLIC NOTICE
CITY OF MAUI
TEXAS COMMUNITY
DEVELOPMENT BLOCK
The City of Maui is giving notice of the City's intent to submit a Texas Community Development Block Grant Program grant...

ADVERTISING FOR BIDS
Forms will be received at the Office of Parks and Recreation Director, Travis County, City of TexasKlan, Arkansas 71104...

Request for Proposal
The City of TexasKlan, Texas, will receive proposals for the construction of a new 250,000 sq ft library building...

NOTICE TO BIDDERS OF THE
RENOVATION OF THE
TEXASKLAN, ARKANSAS TO
LET A CONTRACT FOR THE
RENOVATION OF CITY HALL
RESTROOMS.

NOTICE TO BIDDERS OF THE
RENOVATION OF THE
TEXASKLAN, ARKANSAS TO
LET A CONTRACT FOR THE
RENOVATION OF CITY HALL
RESTROOMS.

NOTICE TO BIDDERS OF THE
RENOVATION OF THE
TEXASKLAN, ARKANSAS TO
LET A CONTRACT FOR THE
RENOVATION OF CITY HALL
RESTROOMS.

NOTICE TO BIDDERS OF THE
RENOVATION OF THE
TEXASKLAN, ARKANSAS TO
LET A CONTRACT FOR THE
RENOVATION OF CITY HALL
RESTROOMS.

NOTICE TO BIDDERS OF THE
RENOVATION OF THE
TEXASKLAN, ARKANSAS TO
LET A CONTRACT FOR THE
RENOVATION OF CITY HALL
RESTROOMS.

NOTICE TO BIDDERS OF THE
RENOVATION OF THE
TEXASKLAN, ARKANSAS TO
LET A CONTRACT FOR THE
RENOVATION OF CITY HALL
RESTROOMS.

Garage Sales
5925 S. 11th St.
TexasKlan, AR
Friday 7:00-2:00
Saturday 7:00-2:00
Sunday 9:00-2:00

Electrifying Services
Whether it's adding outlets or wiring a new addition, you might just find the help you need in this Business Directory.

Cities shrink but immigrants help stem the population losses

TIM HENDERSON
STATIONEER
Continuing a pandemic trend, Americans are moving to the South and Southwest and from cities to the suburbs in search of more space and homes they can afford, recent government data indicates. But immigration, which is starting to bounce back from pandemic lows, has helped mitigate population loss in major cities. A Stateline analysis of U.S. Postal Service change-of-address data from mid-2022 through March shows Americans continuing to pour into suburbs and small cities in the South and Southwest. The same trends showed in recently released U.S. Census Bureau population estimates for mid-2021 to mid-2022.

There is an acceleration of previous trends away from large, expensive, dense urban areas," said Adam Ozimek, chief economist at the Economic Innovation Group, who has analyzed county population loss in 2022 and 2023. Population loss in large cities would have been worse if not for immigrants moving in, Ozimek said. He added that housing prices are rising in cities of the smaller cities that are destinations for movers. The housing shortage in such places, Ozimek said, is partly the result of zoning policies that dissuade developers from building affordable housing. "In a lot of places where people are trying to move, they're not building housing," he said.

The only areas to see outflows of movers between mid-2021 and mid-2022, and drops in population overall, were the central counties within large metropolitan areas. In those areas, a net 629,000 people moved out, compared with the previous year's net exodus of 1.2 million, according to a Stateline analysis using the census estimate and county classifications from the National Center for Health Statistics. But a bump in immigration limited total population loss to only 49,000 in those areas from mid-2021 to mid-2022, compared with 793,000 the previous year.

Those losses could continue: From mid-2022 to earlier this year, Chicago, Los Angeles and New York City ZIP codes had the most people moving out, according to change-of-address forms. The places that gained the most people between mid-2021 and mid-2022 were smaller metro areas with populations under a million, and outlying areas of bigger cities. Address changes since then reflect similar patterns: From mid-2022 through March, people flocked to the Florida cities of Fort Saint Lucie and Ocala, along with The Villages, a retirement mecca south of Ocala. Many people also left Houston for suburban Katy and Austin for Georgetown, north of the Texas capital.

The county with the highest population growth between mid-2021 and mid-2022 was Maricopa County in Arizona, where Phoenix is located. But that county's growth was led by people moving to suburban Surprise and Queen Creek (which straddles Maricopa and Pima counties), according to change-of-address forms from that time. Meanwhile, population loss is straining big city finances. In Los Angeles, for example, the city controller warned in a March report that declining home sales

would make it harder to pay for ambitious plans such as Democratic Mayor Karen Bass' strategy to reduce homelessness. Chicago Mayor-elect Brandon Johnson, a Democrat, has pledged to stop property tax increases he blames for driving people out of the city. But immigrants have mitigated the population loss in big cities. In Miami-Dade County in Florida, immigration more than doubled to about 80,000 between mid-2021 and mid-2022, helping turn the previous year's population loss into a small gain of 3,400. King County, Washington, home of Seattle, experienced a similar turnaround. A record-breaking influx of more than 300,000 Cuban migrants in 2022, many coming over the Southwest border after flights to Central America, deluged places such as Miami and Hudson County, New Jersey. But tighter restrictions on asylum seekers at the U.S.-Mexico border, enacted by the Biden administration earlier this year, have spurred many Cuban and Haitians to get to Florida by boat. That has prompted the administration to start negotiations with Cuba and Florida Republican Gov. Ron DeSantis to call in the National Guard.

In Texas, where immigrants helped compensate for people moving out of Houston and Dallas, Republican Gov. Greg Abbott has made a show of sending buses of migrants from the border to Northeastern cities, though many end up getting off in red states. DeSantis also transported migrants to Northeastern cities and proposed a widespread crackdown on migrants without legal status and those who help them.

The surge in immigration is more of a return to normal than an unusual spike, said Julia Gelatt, senior policy analyst at the nonprofit Migration Policy Institute. It's hard to tell how much of the increase comes from border traffic of migrants entering the country illegally and those seeking asylum, and how much from more typical legal avenues such as work and family visas. Those legal avenues also picked up last year after in-person interviews stalled early in the pandemic. "I wouldn't discount legal immigration as a factor," Gelatt said. "We were under a lot of public health restrictions and those were easing authorities were working through the backlog, and also using new flexibility to waive interviews for a lot of visas, as a way to help more people get into the United States more quickly."

Immigration more than doubled across all types of counties from rural to the most urban between mid-2021 and mid-2022, according to the Stateline analysis of census estimates. Those immigrants might end up moving to more affordable areas, but some may remain in large cities so they can earn higher wages, Ozimek said.

In rural areas and suburbs, immigration also more than doubled between mid-2021 and mid-2022, according to the Stateline analysis. "Rural population change would have been pretty much flat without (immigration)," said Tim Marema, vice president of the Center for Rural Strategies based in Kentucky and Tennessee and editor of the organization's publication, the Daily Yonder.



Janaya Sells, 7, reads a token-bought book on Sept. 26, 2019, during a ribbon cutting for an inchy the Worm book vending machine at F.E. Stevenson Elementary School in Russellville, Ky. For decades, there has been a clash between two schools of thought on how to best teach children to read, with passionate backers on each side of the so-called reading wars. But the approach gaining momentum lately in American classrooms is the so-called science of reading. (Eac Totong/Daily News via AP, File)

An end to the reading wars? More schools embrace phonics

HEATHER HOLLINGSWORTH ASSOCIATED PRESS

Move over "Dick and Jane." A different approach to teaching kids how to read is on the rise. For decades, two schools of thought have clashed on how to best teach children to read, with passionate backers on each side of the so-called reading wars.

The battle has reached into homes via commercials for Hooked on Phonics materials and through shoebox dioramas assigned by teachers seeking to instill a love of literature.

But momentum has shifted lately in favor of the "science of reading." The term refers to decades of research in fields including brain science that point to effective strategies for teaching kids to read.

The science of reading is especially crucial for struggling readers, but school curricula and programs that train teachers have been slow to embrace it.

The approach began to catch on before schools went online in spring 2020.

But a push to teach all students this way has intensified as schools look for ways to regain ground lost during the pandemic — and as parents of kids who can't read demand swift change.

OK, CLASS. TIME FOR A HISTORY LESSON.

One historical approach to teaching reading was known as "whole language." (Close cousins of this approach are "whole word" and "look-say.")

It focused on learning entire words, placing the emphasis on meaning. A famous example is the "Dick and Jane" series, which, like many modern-day books for early readers, repeated words frequently so students could memorize them.

The other approach involved phonics, with supporters arguing students need detailed instruction on the building blocks of reading. That meant lots of time on letter sounds and how to combine them into words.

In 2000, a government-formed National Reading Panel released the findings of its exhaustive examination of the research.

It declared phonics instruction was crucial to teaching young readers, along with several related concepts.

Whole language had lost. What emerged, though, was an informal truce that came to be known as "balanced literacy" and borrowed from both approaches.

The goal: Get kids into books they found enjoyable as quickly as possible.

But in practice, phonics elements often got short shrift, said Michael Kamil, professor emer-

tus of education at Stanford University.

"It wasn't a true compromise," said Kamil, who had sat on the national reading panel.

The approach often led to students learning how to guess words, instead of how to sound them out.

Now, as schools look to address low reading scores, phonics and other elements of the science of reading are getting fresh attention, fueled in part by a series of stories and podcasts by APM Reports.

Textbook makers are adding more phonics, and schools have dumped some popular programs that lacked that approach.

WHAT IS THE SCIENCE OF READING?

While the phrase doesn't have a universal definition, it refers broadly to research in a variety of fields that relates to how a child's brain learns to read. Neuroscientists, for instance, have used MRIs to study the brains of struggling readers.

In practice, this science calls for schools to focus on the building blocks of words. Kindergartners might play rhyming games and clap out the individual syllables in a word to learn to manipulate sounds. Experts call this phonemic awareness.

Students later will learn explicitly how to make letter sounds and blend letters.

To make sure students aren't just guessing at words, teachers might ask them to sound out so-called nonsense words, like "nann" or "zinn."

None is rote memorization of word spellings. Instead, students learn the elements that make up a word. In a lesson using the word "unhappy," students would learn how the prefix "un-" changed the meaning of the base word.

WHY DOES IT MATTER?

For some kids, reading happens almost magically. Bedtime stories and perhaps a little "Sesame Street" are enough.

But 30% to 40% of kids will need the more explicit instruction that is part of the science of reading, said Timothy Shanahan, a professor emeritus at the University of Illinois at Chicago.

Other kids fall somewhere in between. "They're going to learn to read," said Shanahan, also one of the members of the 2000 panel and the former director of reading for Chicago Public Schools. "They're just not going to read as well as they could be or should be."

Complicating the situation, colleges of education often have stuck with balanced literacy de-

See READING, Page 5D

Real estate advertisement for Schimming Company. Includes 'FOR LEASE' sign for 5327 Summerhill Road, 592 SF Office Space, and contact information for Donovan at 903-794-3606.

NEVER MISS A PODCAST. CATCH UP ON YOUR FAVORITES TODAY. Scan the QR code or visit www.texasklan gazette.com/podcast to listen. Both StarClear studio podcasts — On the Line and Tune in TexasKlan — are available free, no Gazette subscription required.

SUBSCRIBER SERVICES 1-501-687-6443 or 1-888-510-6973 REPORT A NEWS TIP 870-330-7619 or clerk@texasklan gazette.com



**CITY OF TEXARKANA ARKANSAS**

**DEPARTMENT OF PUBLIC WORKS**

216 WALNUT ST 71854-6024

P O BOX 2711 TEXARKANA ARKANSAS 75504-2711

PHONE (870) 779-4971 – FAX (870) 773-2395

**Invitation to Bid:** 2,000 Gallon Water Truck – Non CDL

**Deadline:** May 2, 2023 at 2:00 PM, Central Standard Time

**Delivery Location:** Public Works Office

**Purchasing Contact:** Tyler Richards, tyler.richards@txkusa.org

**Date of Issue of Advertisement:** February 4<sup>th</sup> and 11<sup>th</sup> of 2018

No late bids will be accepted. Bids shall be submitted in sealed envelopes labeled "Water Truck Bid" with the name and address of the bidder.

All bids shall be submitted in accordance with the attached City of Texarkana specifications and bid documents attached hereto. Each bidder is required to fill in every blank and shall supply all information requested; failure to do so may be used as basis of rejection.

The undersigned hereby offers to furnish & deliver the articles or services as specified, at the prices & terms stated herein, and in strict accordance with the specifications and general conditions of bidding, all of which are made a part of this offer. This offer is not subject to withdrawal unless upon mutual written agreement by the Proposer/Bidder and City Public Works Director.

Name of Firm: Ledwell & Son Enterprises, Inc.

Contact Person: Tyler Cowling Title: Territory Manager

E-Mail: tcowling@ledwell.com Phone: 501-317-9079

Business Address: 3300 Waco St.

City: Texarkana State: TX Zip: 75501

Signature: Tyler Cowling Date: 04-27-2023

City of Texarkana, Arkansas  
Grapple Truck  
Terms and Conditions

7. Each bidder shall state in the bid document the anticipated number of days from the date of receipt of an order for delivery of equipment and installation to the City of Texarkana. Failure to deliver on or before the time specified in the contract may subject the bidder to payment of damages or other appropriate sanctions.
8. Bidders must provide the City with their bids signed by an employee having legal authority to submit bids on behalf of the bidder. The entire cost of preparing and providing responses shall be borne by the bidder.
9. The City reserves the right to request any additional information it deems necessary from any or all bidders after the submission deadline.
10. The request for bid is not to be construed as an offer, a contract, or a commitment of any kind; nor does it commit the city to pay for any costs incurred by bidder in preparation of bid.
11. If products and/or components other than those described in this bid document are proposed, the bidder must include complete descriptive literature and technical specifications. All requests for additional information must be received within five working days following the request. Each apparent low bid will be reviewed line by line to ensure compliance with specifications prior to recommendation for award.
12. Vendor should call the Public Works Office at (870.779.4977) to ensure receipt of their bid documents prior to opening time and date listed on the bid form.
13. Units must be fully assembled, serviced, and ready for operation as delivered unless otherwise specified. No dealer/distributor logo or other identification will be installed other than standard manufacturer name badges and specification plates.
14. Any reference to a particular brand or manufacturer is done in an effort to establish an acceptable level of quality for this project. Brands or manufacturers that are of equal quality to what is specified will be acceptable for consideration. The City reserves the right to determine if a product is equal to a specified item.
15. **NOTE: Any uncertainties shall be brought to the attention to Tyler Richards immediately via telephone (870.397.0008) or e-mail ( [Tyler.Richards@txkusa.org](mailto:Tyler.Richards@txkusa.org) ). It is the intent and goal of the City of Texarkana to provide bid packets that provide a clear and accurate understanding of the scope of work to be completed and/or goods to be provided. We encourage all interested parties to ask questions to enable all bidders to be on equal bidding terms & documents.**
16. Pursuant to Arkansas Code Annotated §22-9-203 The City of Texarkana encourages all *qualified* small, minority and women business enterprises to bid on and receive contracts for goods, services, and construction. Also, City of Texarkana encourages all

***provide; bid may be rejected for if unable to provide listed items; these are minimum specifications exceeding them is acceptable and should be checked)***

4.1 ENGINE:

- a.  Six Cylinder in line turbo-charged diesel
- b.  210 HP
- c.  110VAC 1000 watt block heater
- d.  Kysor or OEM shutdown system for low engine oil pressure and/or high coolant temperature.

4.2 TRANSMISSION:

- a.  Allison 2500 RDS six-speed with Double Over Drive
- b.  Transmission oil cooler
- c.  PTO provision
- d.  Fluid type: Allison TranSynd

4.3 DRIVETRAIN:

- a.  1710 series heavy-duty main shaft and u-joints
- b.  All u-joints shall have grease fittings installed.

4.4 STEERING:

- a.  Hydraulic power steering

4.5 BRAKES:

- a.  Hydraulic brakes

4.6 FRONT AXLE AND SUSPENSION:

- a.  10,000 lb. capacity rating front axle
- b.  10,000 lb. rated leaf spring suspension
- c.  Heavy-duty double acting shock absorbers
- d.  Front axle shall be designed to allow maximum wheel cut angle
- e.  Mud flaps

4.7 REAR AXLE AND SUSPENSION:

- a.  20,000 lb. rated rear axle
- b.  20,000 lb. rated leaf spring suspension
- c.  Rear end ratio to provide no less than 60 mph nor more than 65 mph @ engine governed RPM.
- d.  Mud flaps

4.8 GROSS VEHICLE WEIGHT RATING:

- a.  26,000 pounds maximum

4.9 ELECTRICAL SYSTEM:

- a.  12 volt



- manufacturer-authorized dealership.
- b.  Manufacturer's warranty shall be provided for each supplemental unit mounted on and delivered with each primary unit.

**6.0 WARRANT SERVICE WORK –**

- 6.1 The successful bidder agrees to begin all major repairs of units within three (3) working days of the date notified by the City of Texarkana and completed within ten (10) days. Major repairs include but are not limited to engine, drive train and packer unit.
- 6.2 The successful bidder agrees to begin all minor repairs within two (2) working days of the date of notification furnished by the City of Texarkana and completed within five (5) days. Minor repairs are any repairs not mentioned in #7.1 above.
- 6.3 If any repairs under this warranty require the unit be returned to the factory, the manufacturer will be responsible for all costs involved with transporting and repair of unit.
- 6.4 Replacement parts shall be delivered within two (2) working days of receipt of order.
- 6.5 The successful bidder may be excluded from future bidding in the City of Texarkana for not completing warranty work in a timely manner as specified in line items #7.1 & #7.2 above.
- 6.6 Warranty work service dealer must be located within a 260-mile radius of the City of Texarkana.

**7.0 STANDARDS –**

- 7.1 Each unit shall meet or exceed the following applicable standards.
- a.  Environmental Protection Agency's Exhaust Emission Standards (EPA)
- b.  Occupational Safety and Health Administration Standards (OSHA)
- c.  Federal Motor Vehicle Safety Standards (Public Law 89-563).
- d.  Arkansas State Highway Commission Regulations regarding vehicle markings, lighting and reflectors.

**8.0 DELIVERY / DOCUMENTATION -**

- 8.1 All units are to be delivered F.O.B. to the City's streets department facility, located at 2601 Dudley St, Texarkana, Arkansas 71854, **for compliance review and final acceptance.**

dealer registration cost for such training.

11.0 **BIDDERS CERTIFICATION AND RESPONSE-**

I certify that I have read and understand the above Minimum Requirements. The unit bid and listed below has the general intent to meet or exceed all of these requirements as specified by The City of Texarkana. Bidder can and will comply with all requirements for documentation and support. I further agree to meet with a representative of the City's Public Works Department and provide all requested information for compliance of specifications prior to bid award recommendation. Bid includes all taxes, fees, and other miscellaneous cost associated with selling this vehicle except the licensing fee to the State of Arkansas for car tags. ***Bid shall NOT include Arkansas sales tax.***

◆ 2,000 Gallon Water Truck: \$ 111,284.24

◆ Delivery Charge: \$ Free Delivery

◆ Please state warranty provided for entire unit bid:

36 months (Warranty Policy's Included in Bid Packet)  
\_\_\_\_\_

**Statement of No Bid – If Applicable**

**In order to assist the Public Works Department of Texarkana in evaluating and improving our solicitation process, we are asking for completion of this form and returning via fax or e-mail. By submitting this form, it will assist us in evaluating all response, improving our bid solicitation process, and to maintain a positive relationship with our vendors.**

We, the undersigned, have declined to bid for the following reason(s):

1. \_\_\_\_\_ We do not offer this service/product
2. \_\_\_\_\_ Our schedule would not permit us to perform
3. \_\_\_\_\_ Unable to meet specifications
4. \_\_\_\_\_ Insufficient time to respond to the Invitation to Bid
5. \_\_\_\_\_ We are unable to meet bond requirements
6. \_\_\_\_\_ Other (Explain)

\*NAME OF FIRM: \_\_\_\_\_

\*BUSINESS ADDRESS: \_\_\_\_\_

\*CITY: \_\_\_\_\_ \*STATE: \_\_\_\_\_ \*ZIP: \_\_\_\_\_

\*PHONE: \_\_\_\_\_ FAX: \_\_\_\_\_

\*E-MAIL ADDRESS: \_\_\_\_\_

\*BY :( PRINTED NAME): \_\_\_\_\_

\*AUTHORIZED SIGNATURE: \_\_\_\_\_

\*TITLE: \_\_\_\_\_ \*DATE: \_\_\_\_\_

\*PLEASE LIST OTHER COMMENTS BELOW:

---

---

---



Ledwell & Son Enterprises, Inc  
 3300 WACO STREET  
 TEXARKANA, TX 75501  
 P: (903) 838-6531  
 F: (903) 831-2737 ext. 9000

Quotation: MQTE0006499

Date: 4/27/2023

PO Number:

**CUSTOMER**

CITY OF TEXARKANA, ARKANSAS  
 PO BOX 2711  
 TEXARKANA, AR 75504-2711  
 P: (870) 779-4991  
 F: (870) 774-3170

**SHIP TO**

CITY OF TEXARKANA, ARKANSAS  
 PO BOX 2711  
 TEXARKANA, AR 75504-2711  
 P: (870) 779-4991  
 F: (870) 774-3170

REQUISITIONER	SHIP VIA	F.O.B.	Estimated Lead Time
	CUSTOMER	FOB Texarkana, TX	

Item Description		Qty
<b>2023 International MV607 w/ LW200WT</b>		
LEDWELL - WATER 2000 GALLON WT		1
Tank Product	Ledwell 2000 Gallon Tank; 120"L x 96"W x 56"T	
Construction	One (1) Longitudinal and one (2) Transverse baffles	
Construction	Rear ladder	
Construction	All-welded subframe Rubber mount padding	
Construction	Hydrant-fill capability Top discharge hydrant-fill water drop	
Construction	Low point drain cocks	
Construction	Suction plumbed interior primer tank	
Construction	Reservoir interior blasted and coated with Tank Liner	
Construction	Water level site tube front mount	
Fenders	Steel fenders with railing	
Hose Reel	Rear mounted hose reel with 50' - 1 1/4" Jet spray hose w/ 1 1/2" nozzle	
Pump	4" X 3" pump - PTO driven Suction and Front/Rear Plumbing	
In-Cab Controls	Standard Air Controls	
Spray Head Configuration	Two (2) front spray heads (unified function)/ Two (2) rear spray heads (unified function) One (1) side spray nozzle with 1 1/2" camlock (independent function) One (1) 3/4" garden hose spigot	
Spray Heads	Standard spray heads	
Bumper	Hose Reel Bumper w/ tool box	
DOT Compliance	Back-up alarm	
DOT Compliance	Mud flaps	

### Quote Totals

Customer and Ledwell agree that any and all sales arising from this Quotation are subject to approval at 3300 Waco Street, Texarkana, TX 75501, and are not final until such approval is granted.

Customer and Ledwell further agree that any agreement arising out of any and all sales connected to this Quotation shall be governed by and construed in accordance with the laws of the State of Texas without regard to applicable principles of conflicts of law. Customer and Ledwell irrevocably consent to the exclusive jurisdiction of any federal or state court located within Bowie County, Texas, in connection with any matter based upon or arising out of such agreement or the matters contemplated herein and agree that process may be served upon them in any manner authorized by the laws of the State of Texas for such persons and waive and covenant not to assert or plead any objection which they might otherwise have to such jurisdiction and such process. Overall vehicle length may vary depending upon chassis cab and axle placement.

<b>Detail Amount</b>	\$111,219.24
<b>DOT</b>	\$65.00
<b>Pre-Freight Amount</b>	\$111,284.24
<b>Freight Amount</b>	\$0.00
<b>Quote Total</b>	\$111,284.24

### Salesperson

TYLER COWLING  
501-317-9079

\_\_\_\_\_  
Authorized By

\_\_\_\_\_  
Date

**\*\*This quote is valid until 06/11/2023 and subject to future material surcharges as applicable.\*\***

**\*\*Applicable State / Local Taxes Not Included\*\***

Please contact your salesperson with any questions. Thank you for your business.

# LEDWELL

## WARRANTY POLICY

Ledwell warranty assures the purchaser that should a defect in material or workmanship occur during the warranty period, Ledwell will assume specific repair responsibilities as listed in this warranty statement. Warranty period shall begin on the date the product is delivered to the customer and continue for one year from that date. The following guidelines should be followed when making repairs to Ledwell equipment whenever possible.

1. All Warranty Claims must be pre-approved prior to beginning of work by a Ledwell authorized warranty representative. A Control Number will be issued and must be included on all approved warranty repair invoices.
2. Reimbursement for parts used in warranty repairs will be credited only when the replacement parts are ordered from and returned to Ledwell & Son Enterprises.
3. All replacement parts sent to the customer will be billed to the customer. The warranty claim will be reviewed, and determination will be made as to its disposal. If approved, replacement parts cost will be credited to the customer.
4. When replacement parts are shipped from Ledwell, freight will be prepaid by Ledwell and will be shipped by the most economical means to arrive in the shortest possible time. Air, Next Day Air, Priority and other special shipments requested by the customer will be at the customer's expense.
5. Replacement parts are only warranted for the remainder of the applicable, original Ledwell Warranty period. In other words, a new warranty period is not established for replacement parts.
6. Warranty labor reimbursement for labor expense to the customer will be paid at the most reasonable and customary rate. Repair times will be reviewed by Ledwell and may be adjusted to average repair times required by other shops to make similar repairs.
7. Reimbursements for repairs made by outside sources other than customer shops will be made for those services deemed necessary for the resolution of the warranty by Ledwell's warranty department. Outside repair invoices must have prior approval from Ledwell's warranty department.
8. In all cases, the most economical repair should be performed unless otherwise directed.
9. Those parts provided by Ledwell used in manufacture of the Ledwell finished product will be covered by our warranty.
10. Service bulletins will be issued when necessary to alert customer of special repairs and maintenance procedures.
11. Approved Claims will be paid in a timely manner.
12. Notice of denied claims will be sent along with a statement as to the reason for the denial within 30 days of receipt of said claim.



3300 Waco Street, Texarkana, TX 75501  
888-LEDWELL | 903.838.6531  
ledwell.com | service@ledwell.com

Not just well made, **LEDWELL MADE.**



## LIMITED WARRANTY FOR MV MODEL SERIES

\* Effective with vehicles built July 01, 2017 or later

### BASIC VEHICLE

Navistar, Inc., at its option, will repair or replace any part of this vehicle that proves defective in material or workmanship, in normal use and service, with new or ReNEWWed® parts, based on the Component Coverages below. Exceptions are listed below:

BASIC VEHICLE COVERAGE	Months	Miles/Km (000)
Basic Vehicle Warranty (See exceptions listed below)	24	Unlimited
Towing (First 90 days see below) (Vehicle Down Situations Only) (See exceptions listed below)	3	Unlimited
<b>Note: Items not listed in warranty exceptions follow base warranty.</b>		
<b>WARRANTY EXCEPTIONS</b>		
CHASSIS COVERAGE	Months	Miles/Km (000)
Frame side rails	84	Unlimited
Cab/cowl structure	60	Unlimited
Cab/cowl perforation corrosion	60	Unlimited
DRIVETRAIN COVERAGE	Months	Miles/Km (000)
Mentor Axles	36	Unlimited
Eaton Precision Transmission	24	Unlimited
MISCELLANEOUS COVERAGE	Months	Miles/Km (000)
Batteries	12	Unlimited
Brightwork, Chassis Paint and Corrosion (other than Cab)	6	Unlimited
Hood/Cab Paint	12	Unlimited

### FIRST 90 DAYS FROM DELIVERY TO USER (DTU)

Correction of loose fasteners, squeaks, rattles and unusual noises. Towing (unless specific coverage is stated above). Adjustments and Maintenance (e.g. air, headlights, adjust brakes/clutch, adjust steering system, check and fill coolant levels).

### WHAT IS NOT INCLUDED UNDER BASIC COVERAGE

#### **Components/Items**

- Warranted by their respective manufacturers (e.g., non-International® brand engines, tires, Allison Transmissions, Eaton Hybrid components, lubricants, etc.)
- Bodies, equipment, and accessories installed by other than authorized International® Truck employees at International® Truck manufacturing plants
- Front and rear axle alignment
- Front & Rear axle coverage excludes brakes, wheel ends, axle shafts, controls & attachments

#### **Repairs & Maintenance**

- Maintenance-related items/repairs, or those, as a result of normal wear and tear, including tune-ups, brake/clutch linings, windshield wiper blades, tire balancing, lubrication, and other similar procedures/parts required to keep vehicle in good working condition
- Failures that are the result of poor fuel quality, water in fuel, rust, etc.
- Repairs needed as a result of vehicle misuse, negligent care, improper maintenance, improper operation, or the result of accident or collision
- Fade, runs, mismatch or damage to paint, trim items, upholstery, chrome, polished surfaces, etc., resulting from environmental causes such as improper polishes, cleaners or washing solutions, or chemical and industrial fallout
- Failure to observe published capacity or load specifications for engine, transmission, propeller shaft, axles (powertrain) and suspension

#### **Other**

- Vehicles sold and/or operated outside the United States and Canada
  - This exception does not apply to vehicles that meet current USA EPA emission standards, which were sold by an International dealer located in Mexico, if the vehicle is authorized by the U.S.D.O.T. to operate in long-haul, cross border transportation and the vehicle is only operated in the United States, Canada, and Mexico
- Vehicles/components that have had unauthorized alterations or modifications
- Vehicles on which the odometer reading has been altered
- Loss of time or use of the vehicle, loss of profits, inconvenience, or other consequential or incidental damages or expenses
- Replacement of defective parts with parts other than those provided by Navistar, Inc



# CITY OF TEXARKANA, AR

## BOARD OF DIRECTORS

**AGENDA TITLE:** Adopt a Resolution declaring Public Works equipment surplus and authorizing disposal in accordance with Arkansas Law. (PWD) Public Works Director Tyler Richards

**AGENDA DATE:** May 15, 2023

**ITEM TYPE:** Ordinance  Resolution  Other :

**DEPARTMENT:** Public Works Department

**PREPARED BY:** Tracie Lee, Assistant Public Works Director

**REQUEST:** Adopt a resolution declaring Public Works equipment surplus and authorizing disposal in accordance with Arkansas Law.

**EMERGENCY CLAUSE:** N/A

**SUMMARY:** A resolution declaring non-running and worn-out Street Department vehicles and equipment not in use to be listed as surplus and disposed of by sell, donation, or trade-in.

### Texarkana Arkansas

### Public Works

### 2023 Equipment Auction

Division	Unit #	Description	VIN	TAG		Cost
141	101	2002 120 JD Track Hoe	044-107255	N/A	Streets	\$25,000.00
141	599	2000 120 JD Track Hoe	S031089	N/A	Streets	\$25,000.00
141	M923	1986 Army Dump Truck 6 x 6 8Yd	C52307946	X21293	Streets	\$ 7,500.00
141	M929	1986 Army Dump Truck 6 x 6 8Yd	C52900998	X20115	Streets	\$ 7,500.00
141	520	95 Chevrolet Pick Up	1GCEC14Z9RZ276410	853TNH	Streets	\$ 5,000.00
141	116	Crafco Chip Seal	9041471EP	N/A	Streets	\$ 500.00
141	10	Rockford Blower	915587	N/A	Streets	\$ 500.00
<b>Total Estimated Value</b>						<b>\$71,000.00</b>

**EXPENSE REQUIRED:** \$0.00



---

**AMOUNT BUDGETED:** \$0.00

---

**APPROPRIATION** \$0.00  
**REQUIRED:**

---

**RECOMMENDED** Acting City Manager and staff recommend board approval.  
**ACTION:**

---

**EXHIBITS:** Resolution

---

# RESOLUTION NO. \_\_\_\_\_

**WHEREAS**, seven (7) items of Public Works Department equipment and vehicles have reached their service life; and

**WHEREAS**, these items should be declared surplus and disposed pursuant to Arkansas law; and

**WHEREAS**, the Acting City Manager and staff recommend approval;

**NOW, THEREFORE, BE IT RESOLVED**, by the Board of Directors of the City of Texarkana, Arkansas, that the equipment and vehicles listed below are hereby declared surplus and may be disposed of in accordance with Arkansas law:

<u>Unit#</u>	<u>Description</u>	<u>VIN#</u>
101	2002 120 JD Track Hoe	044-107255
599	2000 120 JD Track Hoe	S031089
M923	1986 Army Dump Truck 6x6 8Yd	C52307946
M929	1986 Army Dump Truck 6x6 8Yd	C52900998
520	1995 Chevrolet Pick Up	1GCEC14Z9RZ276410
116	Crafco Chip Seal	9041471EP
10	Rockford Blower	915587

**PASSED AND APPROVED** this 15<sup>th</sup> day of May, 2023.

\_\_\_\_\_  
Allen L. Brown, Mayor

**ATTEST:**

\_\_\_\_\_  
Heather Soyars, City Clerk

**APPROVED:**

\_\_\_\_\_  
Joshua L. Potter, City Attorney



# CITY OF TEXARKANA, AR

## BOARD OF DIRECTORS

---

**AGENDA TITLE:** Adopt a Resolution authorizing the Acting City Manager to enter into a Construction Contract with Jack Yates Drywall, Inc., for the Rehabilitation of City Hall Restrooms. (PWD) Public Works Director Tyler Richards

**AGENDA DATE:** May 15, 2023

**ITEM TYPE:** Ordinance  Resolution  Other : \_\_\_\_\_

**DEPARTMENT:** Public Works Department

**PREPARED BY:** Tracie Lee, Assistant Public Works Director

---

**REQUEST:** Adopt a resolution authorizing the Acting City Manager to enter into a Construction Contract with Jack Yates Drywall, Inc., for the Rehabilitation of City Hall Restrooms.

**EMERGENCY CLAUSE:** N/A

---

**SUMMARY:** Adopt a resolution authorizing the Acting City Manager to enter into a construction contract with Jack Yates Drywall, Inc., for the rehabilitation of City Hall restrooms in the amount of forty-four thousand fifty dollars (\$44,050.00) and a contingency in the amount of five thousand nine hundred fifty dollar (\$5,950.00) for any unforeseen issues during construction.

The City solicited sealed bids on April 23<sup>rd</sup> and 30<sup>th</sup>, 2023 for the rehabilitation of City Hall restrooms. Only one bid was received.

Authorization of this construction contract meets all bidding requirements. Funds were budgeted and are available for the purchase.

---

**EXPENSE REQUIRED:** \$50,000.00 (\$44,050.00 bid + \$5,950.00 Contingency)

---

**AMOUNT BUDGETED:** \$50,000.00 (General Fund Reserve)

---

**APPROPRIATION  
REQUIRED:** \$0.00

---

**RECOMMENDED  
ACTION:** Acting City Manager and staff recommend board approval.

---

**EXHIBITS:** Resolution, Bid Ad, and Jack Yates Drywall, Inc., Bid.

---

**RESOLUTION NO. \_\_\_\_\_**

**WHEREAS**, after advertisement a low bid in the amount of \$50,000.00 was submitted by Jack Yates Drywall, Inc., for the rehabilitation of City Hall restrooms; and

**WHEREAS**, funds for the rehabilitation project have been budgeted and are available; and

**WHEREAS**, the Acting City Manager and staff recommend approval;

**NOW, THEREFORE, BE IT RESOLVED**, by the Board of Directors of the City of Texarkana, Arkansas, that the Acting City Manager is authorized to enter into a contract with Jack Yates Drywall, Inc., for the purposes and in the amount set forth above.

**PASSED AND APPROVED** this 15<sup>th</sup> day of May, 2023.

\_\_\_\_\_  
Allen L. Brown, Mayor

**ATTEST:**

\_\_\_\_\_  
Heather Soyars, City Clerk

**APPROVED:**

\_\_\_\_\_  
Joshua L. Potter, City Attorney

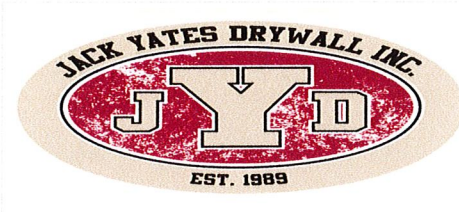

3502 Laurel Street Texarkana, AR 71854-1104 870-772-2223 Fax 870-772-2233

Date: 2/2/2023

To: Public Works  
Re: Restrooms  
Attn: Roger Douglas

**BASEMENT & 1<sup>ST</sup> FLOOR**

1. Demo flooring, toilets, urinals, and vanity sinks and cabinets. (1<sup>st</sup> floor sink to remain)
2. Repair or replace drywall.
3. Scrape acoustical popcorn ceilings.
4. Remove (2) doors and replace with solid core wood doors.
5. Install (2) new cabinet vanities and solid surface tops.
6. Remove existing lights and install new light fixtures.
7. Mud and paint walls.
8. Prep and paint floor in 1<sup>st</sup> floor restroom. Leaving Razorback logo.
9. Install vet and rubber cove base in both basement restrooms.
10. Install new toilets and urinal.
11. New mirrors and accessories.....\$21,500.00

**1<sup>ST</sup> Floor**

1. Prep and paint walls, leaving Hog mural.
2. Install new light and exhaust fan.
3. Install new toilet paper and paper towel disp.
4. Prep and paint floor.
5. Install new solid surface top.....\$5,200.00

**2<sup>nd</sup> FLOOR**

1. Install base cabinets with solid surface tops and new sinks.
2. Install new toilets and flush valves.
3. Install new flush valve for existing urinals.
4. Relocate water heater or install new small one on wall under sink.
5. Install new toilet paper, paper towel and soap dispensers.
6. Hang new mirrors.
7. Prep and paint walls above marble.
8. Replace ceiling tiles.
9. Replace latches on partitions.
10. Install new counter in women's.....\$17,850.00  
An allowance of \$70 per sq. ft. for solid surface tops.

**JACK YATES DRYWALL, Inc.**  
[CLAYJYD@GMAIL.COM](mailto:CLAYJYD@GMAIL.COM)







## CITY OF TEXARKANA, AR BOARD OF DIRECTORS

---

**AGENDA TITLE:** Adopt a Resolution approving the Airport Authority to enter into an agreement with the Yates Foundation, LLC., to name the new terminal the “Jim E. Yates Terminal”. (AIRPORT) Airport Director Paul Mehrlich

**AGENDA DATE:** May 15, 2023

**ITEM TYPE:** Ordinance  Resolution  Other : \_\_\_\_\_

**DEPARTMENT:** Airport

**PREPARED BY:** Paul Mehrlich

---

**REQUEST:** Approve the Airport entering into an agreement with the Yates Foundation, LLC., to name the new terminal the “Jim E. Yates Terminal”.

**EMERGENCY CLAUSE:** N/A

---

**SUMMARY:** Airport will receive \$3,000,000 over two years for a 30-year agreement to name the new terminal the “Jim E. Yates Terminal”.

---

**EXPENSE REQUIRED:** \$

---

**AMOUNT BUDGETED:** \$

---

**APPROPRIATION  
REQUIRED:** 0

---

**RECOMMENDED  
ACTION:**

---

**EXHIBITS:** Resolution, Airport Authority Naming Rights Resolution, Agreement and Brief Sheet.



**RESOLUTION NO. \_\_\_\_\_**

**WHEREAS**, the Texarkana Airport Authority wishes to enter into an agreement with Yates Foundation, LLC., for naming rights of the new Airport Terminal; and

**WHEREAS**, the agreement proposes the new terminal be named the Jim E. Yates Terminal for a term of thirty (30) years in exchange for \$3,000,000.00 payable to the Texarkana Airport Authority in two installments; and

**WHEREAS**, the Acting City Manager and staff recommend approval;

**NOW, THEREFORE, BE IT RESOLVED**, by the Board of Directors of the City of Texarkana, Arkansas, that the Airport Authority is authorized to enter into a contract with Yates Foundation, LLC., for the purposes and in the amount set forth above.

**PASSED AND APPROVED** this 15<sup>th</sup> day of May, 2023.

\_\_\_\_\_  
Allen L. Brown, Mayor

**ATTEST:**

\_\_\_\_\_  
Heather Soyars, City Clerk

**APPROVED:**

\_\_\_\_\_  
Joshua L. Potter, City Attorney

---

---

**Updates/History of Briefing:**

Airport will receive \$3,000,000 over two years for a 30 year agreement to name the new terminal the "Jim E. Yates Terminal".

**Executive Summary and Background Information:**

Approve the Airport entering into an agreement with the Yates Foundation to name the new terminal the "Jim E. Yates Terminal".

**Potential Options:**

- Approve
- Deny

---

---

**Fiscal Implications:**

\$3,000,000.00

**Staff Recommendation:**

Staff recommends for approval.

**Advisory Board/Committee Review:****Board/Committee Recommendation:**

NA

**Advisory Board/Committee Meeting Date and Minutes:**

NA

## NAMING RIGHTS AGREEMENT

THIS NAMING RIGHTS AGREEMENT (“Agreement”) is made and entered this \_\_\_ day of \_\_\_\_\_, 20\_\_\_, by and between the Texarkana Regional Airport Authority (Hereinafter referred to as “Authority”), and **Yates Foundation, LLC**, a corporation organized under the laws of the State of **Texas**, having offices at **2015 Galleria Oaks Texarkana, TX 75503**, and authorized to do business in the State of Arkansas (“Sponsor”):

### RECITALS:

WHEREAS, Authority operates, and maintains the Texarkana Regional Airport, and its facilities, appurtenances, and property; and

WHEREAS, Authority and Sponsor now desire to enter into a naming rights agreement pursuant to which Authority will grant Sponsor temporary exclusive naming rights for Authority’s newly constructed airport passenger terminal located at 2600 TXK Blvd. Texarkana, AR 71854 at the Texarkana Regional Airport;

NOW, THEREFORE, in consideration of the mutual covenants contained herein, and all other good and valuable consideration, the Parties agree as follows:

- (a) **Term.** The term of this Agreement shall commence upon opening of the airport passenger terminal for public use and continue for thirty (30) years, unless otherwise terminated earlier in accordance with the terms, covenants, and conditions contained herein. Upon expiration of the term, Sponsor shall have first rights of refusal for a term extension, of which length shall be negotiated between Authority and Sponsor at that time.
- (b) **Naming Rights Fee.** In consideration of the naming rights and ancillary benefits granted by Authority hereunder, Sponsor agrees to pay a naming rights fee in the amount of three million (\$3,000,000.00) dollars, in the manner and amounts set forth below (“Naming Rights Fee”).
- (c) **Naming Rights Payment Schedule.** Sponsor has the option to pay the Naming Rights Fee to Authority over a period of two (2) years in accordance with the following schedule:

<b>Naming Rights Fee Amount</b>	<b>Due Date</b>
\$1,500,000.00	December 31, 2023
\$1,500,000.00	December 31, 2024
<b>Total: \$3,000,000.00</b>	

Sponsor may accelerate the payment of any or all these fees at any time, at Sponsor’s discretion, so long as the cumulative total of all payments meets the total amount of \$3,000,000.00 by December 31, 2024, as agreed by the Parties. Payments shall be paid by Sponsor in lawful money of the United States, free from all claims, demands, set offs, or counterclaims of any kind against Authority.

**Commented [GH1]:** This is nit picky, but this is an agreement to agreement, which may lead to disputes. However, I do realize that's 30 years from now, so likely not a big deal for you.

- (d) **Acknowledgement.** In consideration for the payment of the Naming Rights Fee and ancillary benefits granted hereunder, Authority agrees to acknowledge Sponsor's naming rights during the term of this Agreement by naming the airport passenger terminal via a mutually agreed upon name. Sponsor has proposed "Jim E. Yates Terminal". In addition to an external name display, Authority and Sponsor may mutually agree to and negotiate other honorary items to include in or near the airport passenger terminal as part of this Agreement ("Naming Rights Items"). Subject to the terms of this Agreement, Sponsor's naming rights will continue for the thirty-year term of this Agreement. Any additional benefits or rights granted to Sponsor beyond those specified in this Agreement must be mutually agreed to by the Parties and are subject to the payment of additional consideration in an amount agreed to by the Parties.
- (e) **Modification of Naming.** If during the term of this Agreement, and following receipt of full payment from Sponsor, the useful life of the airport passenger terminal expires prior to the expiration of this Agreement, the facility is destroyed or severely damaged, then the naming rights under this Agreement will be extended for the length of time necessary to bring the building back to occupational status. Should the building not be rebuilt, then Sponsor will be offered to have their naming rights be applied to equivalent passenger terminal structure, if Sponsor declines then this agreement will cease and Sponsor will be reimbursed for a prorated amount. –be
- (f) **Exclusivity.** Authority agrees to provide exclusive naming rights to Sponsor. Authority will not create additional named areas including but not limited to offices, bathrooms, holding areas, lobby, baggage claim, gates, adjoining parking lots and aircraft ramp, or any other areas directly associated with the aircraft terminal.
- (g) **Termination of Naming.** In addition to any rights and remedies available at law to Authority, Authority may terminate this Agreement and all rights and benefits of Sponsor hereunder, including termination of naming rights and removal of Naming Rights Items upon the occurrence of either of the following:
- a. Sponsor fails to make any payment due under this Agreement; and such default is not cured within thirty (30) days following the date of written notice of default by Authority; or
  - b. In Authority's reasonable opinion, at any time during the term of this Agreement, Sponsor, or the chosen name, have developed or acquired a negative connotation caused by actions of the Sponsor such that the reputation of Texarkana Regional Airport, the Cities of Texarkana, AR and Texarkana, TX and/or Authority is, or might be at risk.

If termination is due to failure of payment, as of the effective date of termination, Authority shall have no further obligation or liability to Sponsor and shall not be required to return any portion of the Naming Rights Fee already received; and Authority may immediately cease to use or display the name and Naming Rights Items. Authority may, in its sole and absolute discretion, determine an alternative recognition for the portion of the payment already received.

**Commented [GH2]:** I recommend finalizing the name and where the name will be shown (location, size, font, etc.) and including that in this Agreement – perhaps an exhibit showing how it will be displayed.

Also, make sure this the only naming right for this termination. For example, I've seen someone pay a ton of money for stadium rights, but then the school sold the naming rights to the actual football field. I recall that upsetting the person. You want to understand what other naming rights are being sold related to that terminal.

**Commented [DTA3R2]:** I will modify the text, I believe the current plan is for it to be the Jim E. Yates Terminal. I will include an Exhibit of a mockup.

If termination is due to a change in circumstances such that Authority determines Sponsor or the chosen name of the airport passenger terminal have developed or acquired a negative connotation caused by actions of the Sponsor that may or does put the reputation of Texarkana Regional Airport, the Cities of Texarkana, AR and Texarkana, TX, and/or Authority at risk, Sponsor shall not be entitled to a refund or any portion of the payment made; and Authority may immediately cease to use or display the name and Naming Rights Items.

Should Sponsor decide to end affiliation with Authority during the timeframe outlined in this Agreement, Sponsor will be responsible for the payment to remove the Naming Rights Items from the airport passenger terminal.

- (h) **Promotion.** During the term of this Agreement, Authority, in consideration of the naming rights and benefits conferred hereunder, shall have the right, without charge, to photograph, use the names, likenesses, and images of the Naming Rights Items in photographic, audiovisual, digital or any other form of media (“Media Materials”) and to use, reproduce, distribute, exhibit, and publish the Media Materials in any manner, in whole or in part, in Authority brochures, website postings, informational and marketing materials, and reports and publications.
- (i) **No Endorsement.** By entering into this Agreement, Authority neither directly nor indirectly endorses any product or service provided, or to be provided, by Sponsor whether related to this Agreement or not. Sponsor will not state or imply that this Agreement is an endorsement by Authority or its associates.
- (j) **Indemnification by Sponsor.** Sponsor agrees to protect, defend, indemnify Authority, including for purposes of this section its Board members, officers, agents, employees, volunteers, and others acting on its behalf, and to hold Authority completely harmless to the extent allowed by general law, from and against any and all claims, demands, damages, liability, losses, payments, suits, actions, proceedings, or judgments of every nature and description, including attorney’s fees and other litigation expenses, arising out of or incidental to Sponsor’s acts, omissions or breach of this Agreement and/or any litigation, arbitration, hearing, governmental inquiry or investigation or other proceeding commenced by any third party alleging or arising from claims of wrongful conduct or omission by Sponsor including, but not limited to, negligence, libel, slander, improper trade practice, illegal competition, copyright infringement, trademark infringement, license infringement, breach of warranty, and unsafe, hazardous or defective product or service, except to the extent that such claims, demands, damages, liability, losses, payments, suits, actions, proceedings, or judgments and costs incident thereto are caused by the negligence or intentional misconduct of any party seeking indemnification hereunder.
- (k) **Indemnification by Authority.** Authority agrees to protect, defend, indemnify Sponsor, including for purposes of this section its Board members, officers, agents, employees, volunteers, and others acting on its behalf, and to hold Sponsor completely harmless to the extent allowed by general law, from and against any and all claims, demands, damages,

liability, losses, payments, suits, actions, proceedings, or judgments of every nature and description, including attorney's fees and other litigation expenses, arising out of or incidental to Authority's acts, omissions or breach of this Agreement and/or any litigation, arbitration, hearing, governmental inquiry or investigation or other proceeding commenced by any third party alleging or arising from claims of wrongful conduct or omission by Authority including, but not limited to, negligence, libel, slander, improper trade practice, illegal competition, copyright infringement, trademark infringement, license infringement, breach of warranty, and unsafe, hazardous or defective product or service, except to the extent that such claims, demands, damages, liability, losses, payments, suits, actions, proceedings, or judgments and costs incident thereto are caused by the negligence or intentional misconduct of any party seeking indemnification hereunder.

- (l) **Liability.** Under no circumstances shall the Parties be liable to one another for any consequential, special, indirect, incidental, punitive, exemplary or aggravated loss, damage, cost, or expense of any kind.
- (m) **Ownership.** Sponsor acknowledges that, at all times, the ownership of the airport passenger terminal remains with Authority.
- (n) **Entire Agreement.** This Agreement, consisting of **Sections a-q**, constitutes the entire agreement of the Parties on the subject matter hereof and supersedes all prior relevant agreements between the Parties. This Agreement may not be changed, modified, or discharged except by written instrument duly executed by the duly authorized representatives of Authority and Sponsor. Sponsor agrees that no representations or warranties shall be binding upon Authority unless expressed in writing in this Agreement or by valid amendment.
- (o) **Non-Waiver.** Failure of either party to enforce any provision of this Agreement is not construed as a waiver of that provision or of either party's right to enforce that provision or any other provision of this Agreement.
- (p) **Binding Dispute/Forum.** Prior to litigation the Parties shall engage in mediation as a condition precedent to any form of binding dispute resolution. Any litigation or other proceeding to enforce or interpret the provisions of this Agreement or the Parties' rights and liabilities arising out of this Agreement of the performance hereunder shall be instituted or maintained only in any state or federal courts of Miller County, Arkansas. Sponsor shall pay the cost of collection and reasonable attorney's fees whenever Authority retains the service of an attorney to collect overdue payments or to enforce any other term, covenant or condition set forth in this Agreement.
- (q) **Choice of Law.** This Agreement shall be deemed to have been made in and be construed in accordance with the laws of the State of Arkansas.
- (r) **Relationship of Parties.** The relationship between Authority and Sponsor shall, always and only, be that of Authority and Sponsor. Sponsor shall never at any time during the term

**Commented [GH4]:** This may be fine, but just pointing out that governing law and venue is in Arkansas (not Texas).

of this Agreement become the agent of Authority, and Authority shall not be responsible for the acts or omissions of Sponsor.

**\*\*remainder of page intentionally left blank\*\***

IN WITNESS WHEREOF, the Parties have made and executed this Agreement on the \_\_\_\_ day of \_\_\_\_\_, 20\_\_\_\_.

**NAMING RIGHTS AGREEMENT BETWEEN TEXARKANA REGIONAL AIRPORT AUTHORITY**

**AND**

\_\_\_\_\_

**(SPONSOR)**

**SPONSOR**

Signature: \_\_\_\_\_ Printed Name: \_\_\_\_\_

Title: \_\_\_\_\_ Date: \_\_\_\_\_

**TEXARKANA REGIONAL AIRPORT AUTHORITY**

Signature: \_\_\_\_\_ Printed Name: \_\_\_\_\_

Title: \_\_\_\_\_ Date: \_\_\_\_\_

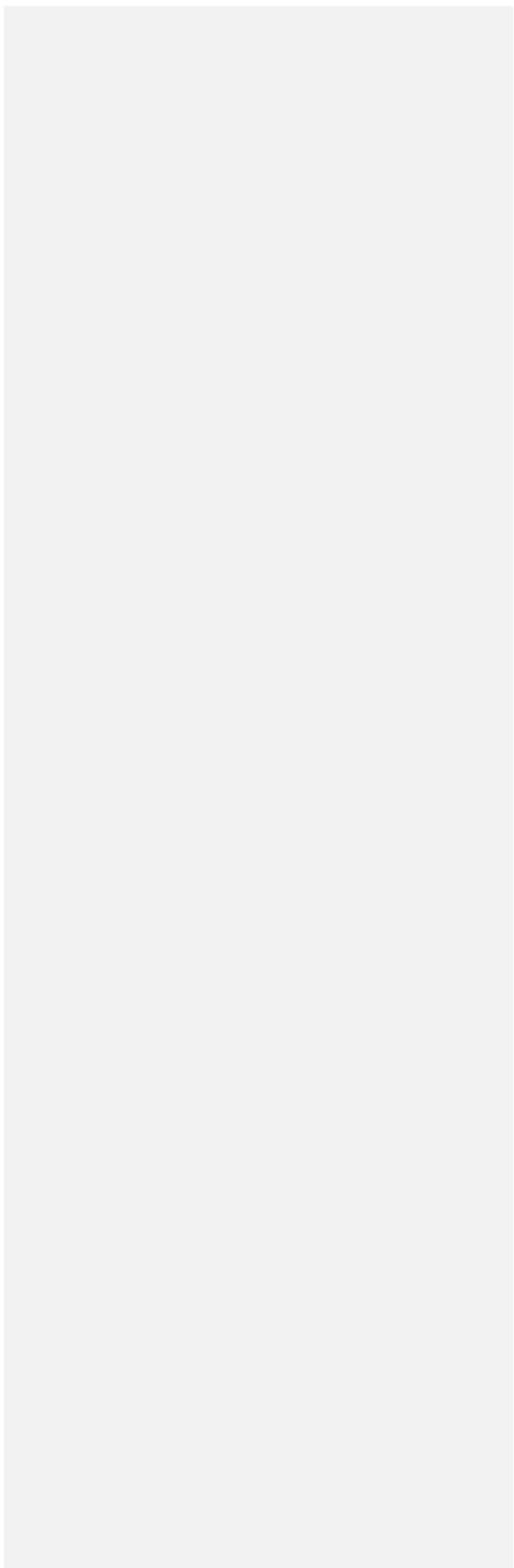
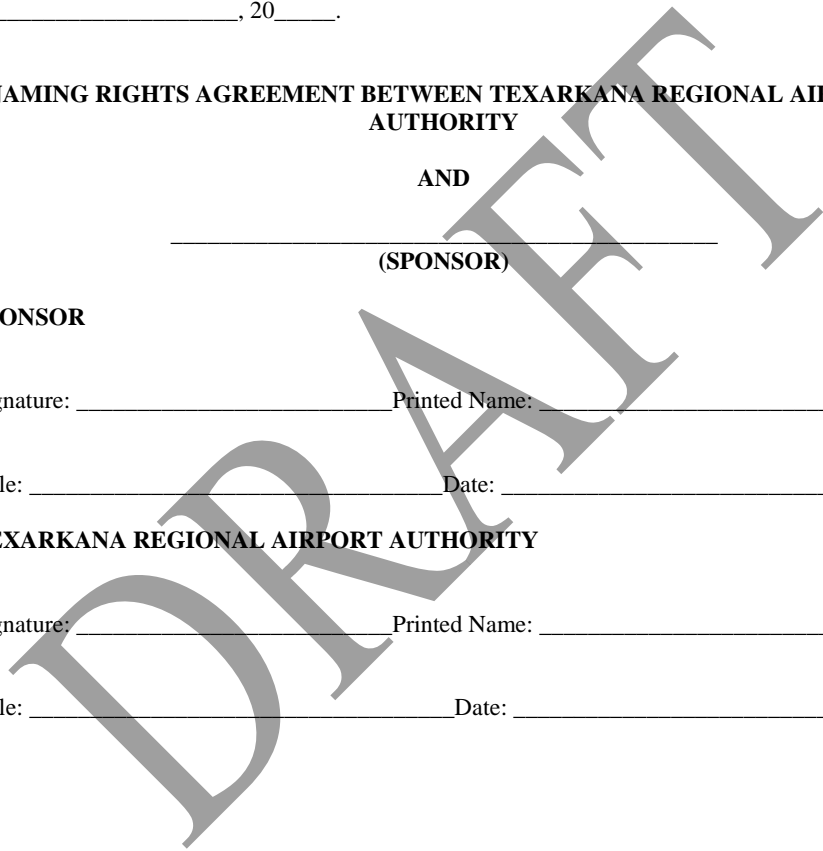

**Exhibit A**  
**Rendering of Jim E. Yates Terminal**



DRAFT



**TEXARKANA AIRPORT AUTHORITY RESOLUTION No. 042723  
BE IT RESOLVED by the TEXARKANA AIRPORT AUTHORITY TO ENTER  
INTO AN AGREEMENT WITH YATES FOUNDATION LLC FOR NAMING  
RIGHTS OF THE NEW AIRPORT TERMINAL**

**WHEREAS, the Airport Authority is entrusted with the power of planning, developing, construction, enlargement, and improvement of the Texarkana Regional Airport; and**

**WHEREAS, the Texarkana Regional Airport Authority was formed under Arkansas Code § 14-361-101 to be jointly owned by the cities of Texarkana AR and Texarkana TX; and**

**WHEREAS, The city of Texarkana Arkansas Code § 6-31-1 indicates that except upon joint approval of the cities' governing bodies, no contractual obligation shall be entered by the authority for a term greater than five (5) years; and,**

**WHEREAS, The city of Texarkana Texas Code § 4-25-1 indicates that except upon joint approval of the cities' governing bodies, no contractual obligation shall be entered by the authority for a term greater than five (5) years; and,**

**WHEREAS, Yates Foundation LLC has agreed to terms for naming rights for the new terminal; and,**

**WHEREAS, Yates Foundation LLC has agreed to pay \$3,000,000 to Texarkana Airport Authority in two equal installments; and,**

**WHEREAS, Yates Foundation LLC has proposed the name Jim E. Yates Terminal; and,**

**WHEREAS, Jim E. Yates served both the community and airport in multiple capacities over his life;**

**NOW, THEREFORE, BE IT RESOLVED BY THE TEXARKANA AIRPORT AUTHORITY THAT:**

**SECTION 1. Mr. Ferdinand Mehrlich, Airport Executive Director is authorized to sign a 30-year naming rights agreement with Yates Foundation LLC to name the new Airport Terminal the "Jim E. Yates Terminal" and Mrs. Robin Hickerson is authorized to witness said signing.**

**SECTION 2. This Resolution shall take effect immediately upon adoption by both the City of Texarkana Arkansas and the City of Texarkana Texas.**

**Adopted this 27<sup>th</sup> day of April, 2023**

**ATTEST**

  
\_\_\_\_\_  
**Ferdinand P Mehrlich III, Director**

**SIGNED**

  
\_\_\_\_\_  
**Robin Hickerson, Chair**





# CITY OF TEXARKANA, AR

## BOARD OF DIRECTORS

---

<b>AGENDA TITLE:</b>	Adopt a Resolution to accept the proposed redistricting wards map. (ADMIN) Acting City Manager/Finance Director TyRhonda Henderson
<b>AGENDA DATE:</b>	May 15, 2023
<b>ITEM TYPE:</b>	Ordinance <input type="checkbox"/> Resolution <input checked="" type="checkbox"/> Other <input type="checkbox"/> : _____
<b>DEPARTMENT:</b>	Board of Directors
<b>PREPARED BY:</b>	Heather Soyars, City Clerk

---

<b>REQUEST:</b>	Accept the proposed redistricting wards map.
<b>EMERGENCY CLAUSE:</b>	N/A

---

<b>SUMMARY:</b>	<p>After the 2020 census, a substantial change in the population of multiple wards required the Board to redistrict the wards to make them substantially equal as possible.</p> <p>A Redistricting Contract was signed with DataScout, LLC., in January 2022. A workshop was held on August 25, 2022, one on February 6, 2023, with additional requests made from Directors.</p> <p>A workshop was held on May 1, 2023, with Valerie Love, DataScout, LLC., Data and Special Projects Manager on site with a consensus of the Board on the proposed redistricting map.</p>
-----------------	--

---

<b>EXPENSE REQUIRED:</b>	N/A
<b>AMOUNT BUDGETED:</b>	N/A
<b>APPROPRIATION REQUIRED:</b>	N/A

---

<b>RECOMMENDED ACTION:</b>	Board approval to accept the proposed redistricting map.
----------------------------	--

---

<b>EXHIBITS:</b>	Resolution and map
------------------	--------------------

# RESOLUTION NO. \_\_\_\_\_

**WHEREAS**, redistricting of the City is necessary because of information received from the 2020 Census; and

**WHEREAS**, proposed redistricting maps were prepared by DataScout, LLC., and multiple workshops were held before the Board reached a consensus on the proposed redistricting map; and

**WHEREAS**, the redistricting maps are based on the City's current 6-1 type of government;

**WHEREAS**, the Acting City Manager and staff recommend approval;

**NOW, THEREFORE, BE IT RESOLVED**, by the Board of Directors of the City of Texarkana, Arkansas, that the 6-1 type of government, six wards with an elected representative from each ward and one elected mayor at-large, continue in effect and that the proposed 6-1 redistricting map is accepted and approved.

**PASSED AND APPROVED** this 15<sup>th</sup> day of May, 2023.

\_\_\_\_\_  
Allen L. Brown, Mayor

**ATTEST:**

\_\_\_\_\_  
Heather Soyars, City Clerk

**APPROVED:**

\_\_\_\_\_  
Joshua L. Potter, City Attorney

# Redistricting Final Report

## Texarkana City Council Wards

### Table of Contents

Redistricting Summary ..... 2

District Descriptions ..... 3

--District: 1 ..... 3

--District: 2 ..... 6

--District: 3 ..... 13

--District: 4 ..... 18

--District: 5 ..... 22

--District: 6 ..... 23

District Maps ..... 26

--Overview ..... 26

--District: 1 ..... 27

--District: 2 ..... 28

--District: 3 ..... 29

--District: 4 ..... 30

--District: 5 ..... 31

--District: 6 ..... 32

Adoption ..... 33

# Redistricting Final Report

## Texarkana City Council Wards

### Redistricting Summary

In accordance with Arkansas State Law 14-43-311/14-44-102, Texarkana City Council in the State of Arkansas does hereby adopt the districts contained in this report. Each section includes population and demographic figures associated with the district that is described based upon the data contained the U.S. Public Law 94 - 171, from the United States Census of Population of 2020. Each row of the report lists the unique numeric identification code assigned by the U.S. Census Bureau for the geographic unit contained therein. These unique areas represent Counties, Voting Tabulation Districts, and blocks that when combined altogether compose the geographic territory of the district. This listing serves as the written description of the districts.

At the direction of the redistricting authority of Miller County the 2020 Census Population counts for the blocks identified in the list below were reduced by the calculated number of felons incarcerated to avoid diluting the vote of voters in the adjoining districts of the jurisdiction. The State of Arkansas classifies incarcerated felons as ineligible to vote. The State of Arkansas, Constitutional Amendment 51, § 9. Application to Register states that "(a) All persons may register who: (1) have not been convicted of a felony unless the person's sentence has been discharged or the person has been pardoned;". Unless otherwise noted, other demographic counts such as race were reduced in these blocks by the same percentage as the overall population.

**Census Block Geold:** 050910205002076

**Correctional Facility:** Miller County Sheriffs Office and Detention Center  
**Description:**

**Census Block Geold:** 050910205002077

**Correctional Facility:** Miller County Sheriffs Office and Detention Center  
**Description:**

**Census Block Geold:** 050910204001044

**Correctional Facility:** Southwest Arkansas Correction Center and Texarkana Regional Correction Center  
**Description:**

District	Total Population	Target Population	Deviation	Percent Deviation	White	Black	Asian	Native American	Hawaiian Pacific Islander	Hispanic	Multiple	Other
1	4640	4784	-144	-3.01	3620	566	15	31	2	194	198	15
2	4692	4784	-92	-1.92	1556	2542	12	34	0	300	237	11
3	4700	4784	-84	-1.76	1985	2209	28	22	0	220	217	19
4	4840	4784	56	1.17	2500	1798	40	22	0	207	269	4
5	4931	4784	147	3.07	2733	1831	18	23	0	154	158	14
6	4903	4784	119	2.49	3214	1252	61	26	0	144	167	39

# Redistricting Final Report

## Texarkana City Council Wards

### District Descriptions

**District: 1**

Split	Block	Corr. Facil.	Geo ID	Total Population	White	Black	Asian	Native American	Hawaiian Pacific Islander	Hispanic	Multiple	Other
	1000		050910210011000	175	160	11	0	0	0	3	1	0
	1001		050910210011001	111	97	0	0	3	0	6	5	0
	1002		050910210011002	51	40	0	2	0	0	4	2	3
	1003		050910210011003	0	0	0	0	0	0	0	0	0
	1004		050910210011004	26	19	4	0	0	0	2	1	0
	1008		050910210011008	4	4	0	0	0	0	0	0	0
	1010		050910208021010	13	4	1	0	4	0	0	4	0
	1011		050910208021011	43	34	0	1	0	0	2	6	0
	1011		050910210011011	47	36	0	0	0	0	4	7	0
	1012		050910208021012	84	75	5	0	0	0	2	2	0
	1015		050910208021015	8	7	0	0	0	0	0	1	0
	1016		050910208021016	179	171	3	0	3	0	2	0	0
	1017		050910208021017	11	10	0	0	0	0	0	1	0
	1018		050910208021018	84	76	2	0	0	0	1	5	0
	1019		050910208021019	70	69	0	0	0	0	1	0	0
	1020		050910208021020	20	15	0	0	0	0	2	3	0
	1021		050910208021021	56	51	0	1	1	0	1	2	0
	1021		050910210011021	24	18	1	0	0	0	0	4	1
	1022		050910208021022	13	9	1	0	0	0	3	0	0
	1022		050910210011022	22	8	7	0	0	0	1	6	0
	1022		050910209021022	12	3	1	0	0	0	8	0	0
	1023		050910208021023	41	38	0	0	0	0	0	3	0
	1024		050910208021024	0	0	0	0	0	0	0	0	0
	1025		050910208021025	23	16	3	0	0	0	0	4	0
	1027		050910209021027	64	63	0	0	0	0	1	0	0
	1029		050910209021029	74	72	0	0	1	1	0	0	0
	1030		050910209021030	6	5	0	0	0	0	1	0	0
	1031		050910209021031	5	5	0	0	0	0	0	0	0
	1031		050910210011031	26	21	3	0	0	0	1	1	0
	1032		050910210011032	8	8	0	0	0	0	0	0	0
	1033		050910209021033	134	113	14	2	0	0	5	0	0
	1038		050910209021038	52	47	0	0	3	0	2	0	0
	1039		050910209021039	19	18	0	0	0	0	0	1	0
	1040		050910209021040	45	38	0	0	1	0	0	6	0
	1041		050910209021041	5	4	1	0	0	0	0	0	0
	2000		050910210022000	0	0	0	0	0	0	0	0	0
	2000		050910208022000	13	7	0	1	0	0	3	0	2
	2001		050910208022001	18	12	0	0	0	0	6	0	0
	2002		050910208022002	0	0	0	0	0	0	0	0	0
	2003		050910208022003	10	6	0	0	0	0	4	0	0
	2004		050910209022004	36	30	4	0	0	0	0	2	0
	2005		050910209022005	12	7	5	0	0	0	0	0	0
	2006		050910209022006	39	36	1	0	1	0	0	1	0

## Redistricting Final Report

## Texarkana City Council Wards

2007	050910209022007	28	22	2	0	1	0	2	1	0
2008	050910208022008	13	7	3	0	0	0	3	0	0
2009	050910208022009	14	12	0	0	0	0	0	0	2
2010	050910208022010	17	13	2	0	0	0	0	1	1
2011	050910209022011	34	32	1	0	0	0	0	1	0
2011	050910208022011	0	0	0	0	0	0	0	0	0
2012	050910208022012	4	4	0	0	0	0	0	0	0
2012	050910209022012	126	121	2	0	0	0	2	1	0
2013	050910209022013	4	4	0	0	0	0	0	0	0
2013	050910208022013	21	21	0	0	0	0	0	0	0
2014	050910209022014	25	25	0	0	0	0	0	0	0
2014	050910208022014	49	46	0	0	0	0	0	3	0
2015	050910208022015	17	13	1	0	0	0	2	1	0
2015	050910209022015	5	0	0	2	1	0	2	0	0
2016	050910209022016	49	45	3	0	0	0	1	0	0
2016	050910208022016	12	3	1	0	0	0	7	1	0
2017	050910209022017	1	0	0	0	0	0	1	0	0
2017	050910208022017	0	0	0	0	0	0	0	0	0
2018	050910209022018	45	42	3	0	0	0	0	0	0
2019	050910209022019	103	101	1	0	0	0	1	0	0
2020	050910209022020	7	6	1	0	0	0	0	0	0
2021	050910209022021	49	43	2	0	0	0	3	1	0
2022	050910209022022	51	41	3	0	0	0	3	4	0
2023	050910209022023	58	58	0	0	0	0	0	0	0
2023	050910208022023	11	7	1	0	0	0	1	2	0
2024	050910209022024	11	7	0	1	0	0	0	3	0
2025	050910209022025	26	26	0	0	0	0	0	0	0
2026	050910209022026	22	14	0	1	0	0	5	2	0
2027	050910209022027	24	20	0	0	0	0	4	0	0
2028	050910209022028	23	15	4	0	0	0	1	3	0
2029	050910209022029	10	6	1	0	1	0	2	0	0
2032	050910209022032	71	57	6	0	0	0	2	6	0
2033	050910209022033	17	16	0	0	0	0	1	0	0
2034	050910209022034	32	26	3	0	0	0	0	3	0
2035	050910209022035	7	7	0	0	0	0	0	0	0
2036	050910209022036	4	0	1	0	0	0	1	2	0
2037	050910209022037	25	19	0	0	3	0	2	1	0
2038	050910209022038	35	32	0	0	0	0	0	3	0
2045	050910209022045	17	6	4	0	0	0	0	5	2
2068	050910205002068	0	0	0	0	0	0	0	0	0
2069	050910205002069	0	0	0	0	0	0	0	0	0
2070	050910205002070	10	4	6	0	0	0	0	0	0
2071	050910205002071	0	0	0	0	0	0	0	0	0
2072	050910205002072	0	0	0	0	0	0	0	0	0
2073	050910205002073	13	13	0	0	0	0	0	0	0
2074	050910205002074	41	31	8	0	0	0	1	1	0
2076	* 050910205002076	94	56	27	0	1	1	7	3	0
2077	* 050910205002077	211	122	74	1	0	0	13	1	0
2078	050910205002078	39	30	2	0	0	0	6	1	0

## Redistricting Final Report

## Texarkana City Council Wards

2079	050910205002079	0	0	0	0	0	0	0	0	0
2080	050910205002080	19	3	14	0	0	0	2	0	0
2081	050910205002081	9	1	4	0	1	0	2	1	0
2082	050910205002082	13	8	2	0	1	0	2	0	0
2083	050910205002083	12	5	5	0	2	0	0	0	0
2100	050910205002100	0	0	0	0	0	0	0	0	0
2101	050910205002101	7	4	2	0	0	0	0	1	0
2105	050910205002105	11	7	0	0	0	0	3	1	0
2106	050910205002106	12	9	1	0	0	0	1	1	0
2107	050910205002107	16	12	2	0	0	0	2	0	0
2108	050910205002108	3	0	3	0	0	0	0	0	0
2109	050910205002109	4	0	0	0	0	0	4	0	0
2110	050910205002110	6	1	2	0	0	0	3	0	0
3000	050910208023000	37	33	2	0	0	0	0	1	1
3000	050910204003000	0	0	0	0	0	0	0	0	0
3001	050910208023001	0	0	0	0	0	0	0	0	0
3001	050910204003001	0	0	0	0	0	0	0	0	0
3002	050910208023002	13	10	1	0	0	0	0	2	0
3002	050910204003002	26	17	6	0	0	0	1	2	0
3003	050910204003003	27	5	17	0	0	0	4	1	0
3003	050910208023003	14	6	0	0	0	0	4	4	0
3004	050910208023004	77	69	5	0	0	0	0	3	0
3004	050910204003004	44	37	4	0	0	0	2	1	0
3005	050910204003005	46	37	6	0	0	0	3	0	0
3005	050910208023005	0	0	0	0	0	0	0	0	0
3006	050910204003006	107	102	5	0	0	0	0	0	0
3006	050910208023006	0	0	0	0	0	0	0	0	0
3007	050910204003007	4	1	0	2	0	0	1	0	0
3007	050910208023007	5	2	3	0	0	0	0	0	0
3008	050910208023008	7	4	0	0	0	0	3	0	0
3008	050910204003008	24	16	0	0	0	0	1	4	3
3009	050910208023009	94	84	2	0	0	0	3	5	0
3009	050910204003009	309	83	214	0	0	0	2	10	0
3010	050910204003010	8	7	0	0	0	0	0	1	0
3010	050910208023010	39	31	5	0	0	0	1	2	0
3011	050910204003011	15	11	0	0	0	0	1	3	0
3011	050910208023011	75	67	5	0	0	0	1	2	0
3012	050910204003012	21	16	0	0	0	0	1	4	0
3012	050910208023012	29	18	4	0	0	0	0	7	0
3013	050910208023013	0	0	0	0	0	0	0	0	0
3013	050910204003013	0	0	0	0	0	0	0	0	0
3014	050910204003014	1	0	1	0	0	0	0	0	0
3014	050910208023014	0	0	0	0	0	0	0	0	0
3015	050910204003015	2	1	0	0	0	0	0	1	0
3015	050910208023015	0	0	0	0	0	0	0	0	0
3016	050910204003016	4	1	0	0	0	0	2	1	0
3016	050910208023016	0	0	0	0	0	0	0	0	0
3016	050910209023016	15	7	0	0	0	0	0	8	0
3017	050910204003017	7	5	2	0	0	0	0	0	0



# Redistricting Final Report

## Texarkana City Council Wards

3017	050910209023017	18	12	2	0	0	0	0	4	0
3018	050910208023018	55	48	5	1	0	0	1	0	0
3018	050910209023018	64	63	0	0	0	0	1	0	0
3018	050910204003018	8	7	1	0	0	0	0	0	0
3019	050910204003019	8	6	1	0	1	0	0	0	0
3019	050910209023019	0	0	0	0	0	0	0	0	0
3020	050910204003020	11	9	2	0	0	0	0	0	0
3020	050910209023020	4	1	1	0	0	0	2	0	0
3021	050910204003021	4	2	0	0	0	0	1	1	0
3022	050910204003022	22	21	1	0	0	0	0	0	0
3022	050910209023022	33	24	4	0	0	0	0	5	0
3023	050910204003023	27	23	3	0	1	0	0	0	0
3035	050910209023035	0	0	0	0	0	0	0	0	0
3044	050910209023044	7	7	0	0	0	0	0	0	0
3045	050910209023045	28	28	0	0	0	0	0	0	0
3048	050910209023048	0	0	0	0	0	0	0	0	0
3088	050910209023088	10	8	0	0	0	0	0	2	0
3090	050910209023090	13	10	0	0	1	0	0	2	0
3091	050910209023091	8	6	0	0	0	0	2	0	0

### District: 2

Split	Block	Corr. Facil.	Geo ID	Total Population	White	Black	Asian	Native American	Hawaiian Pacific Islander	Hispanic	Multiple	Other
	1000		050910205001000	9	8	1	0	0	0	0	0	0
	1000		050910204001000	0	0	0	0	0	0	0	0	0
	1000		050910206001000	1	0	0	0	0	0	1	0	0
	1001		050910206001001	5	0	5	0	0	0	0	0	0
	1001		050910204001001	21	16	0	0	0	0	4	1	0
	1001		050910205001001	11	11	0	0	0	0	0	0	0
	1002		050910205001002	23	8	14	0	0	0	1	0	0
	1002		050910204001002	7	3	3	0	0	0	1	0	0
	1002		050910206001002	3	3	0	0	0	0	0	0	0
	1003		050910206001003	13	0	11	0	0	0	2	0	0
	1003		050910204001003	9	4	2	0	0	0	0	3	0
	1003		050910205001003	24	8	16	0	0	0	0	0	0
	1004		050910204001004	0	0	0	0	0	0	0	0	0
	1004		050910205001004	18	0	14	0	1	0	3	0	0
	1004		050910206001004	3	1	2	0	0	0	0	0	0
	1005		050910206001005	3	0	3	0	0	0	0	0	0
	1005		050910204001005	1	0	0	0	0	0	0	0	1
	1005		050910205001005	27	2	25	0	0	0	0	0	0
	1006		050910205001006	9	1	8	0	0	0	0	0	0
	1006		050910204001006	0	0	0	0	0	0	0	0	0
	1006		050910206001006	0	0	0	0	0	0	0	0	0
	1007		050910204001007	14	0	13	0	0	0	1	0	0
	1007		050910205001007	0	0	0	0	0	0	0	0	0
	1007		050910206001007	9	0	8	0	0	0	0	1	0
	1008		050910204001008	0	0	0	0	0	0	0	0	0

## Redistricting Final Report

## Texarkana City Council Wards

1008	050910205001008	7	0	5	0	0	0	2	0	0
1008	050910206001008	9	0	9	0	0	0	0	0	0
1009	050910206001009	17	0	15	0	0	0	2	0	0
1009	050910204001009	8	2	3	1	0	0	2	0	0
1009	050910205001009	8	1	1	0	0	0	5	1	0
1010	050910204001010	12	9	0	0	0	0	3	0	0
1010	050910205001010	16	1	14	0	0	0	0	1	0
1010	050910206001010	7	0	7	0	0	0	0	0	0
1011	050910206001011	7	0	6	0	0	0	1	0	0
1011	050910204001011	0	0	0	0	0	0	0	0	0
1011	050910205001011	14	0	13	0	1	0	0	0	0
1012	050910205001012	10	0	6	0	0	0	1	3	0
1012	050910206001012	38	0	37	0	0	0	1	0	0
1012	050910204001012	0	0	0	0	0	0	0	0	0
1013	050910204001013	0	0	0	0	0	0	0	0	0
1013	050910205001013	0	0	0	0	0	0	0	0	0
1013	050910206001013	7	0	6	0	0	0	1	0	0
1014	050910205001014	0	0	0	0	0	0	0	0	0
1014	050910204001014	7	2	3	0	0	0	2	0	0
1014	050910206001014	32	12	20	0	0	0	0	0	0
1015	050910206001015	19	0	17	0	0	0	2	0	0
1015	050910204001015	8	1	4	0	0	0	2	1	0
1015	050910205001015	16	8	1	0	0	0	1	5	1
1016	050910205001016	25	14	9	0	0	0	2	0	0
1016	050910204001016	15	1	7	0	0	0	2	5	0
1016	050910206001016	12	1	10	0	0	0	0	1	0
1017	050910205001017	14	5	9	0	0	0	0	0	0
1017	050910204001017	0	0	0	0	0	0	0	0	0
1017	050910206001017	3	2	1	0	0	0	0	0	0
1018	050910204001018	0	0	0	0	0	0	0	0	0
1018	050910205001018	0	0	0	0	0	0	0	0	0
1018	050910206001018	1	0	1	0	0	0	0	0	0
1019	050910204001019	0	0	0	0	0	0	0	0	0
1019	050910205001019	8	5	1	0	0	0	2	0	0
1019	050910206001019	0	0	0	0	0	0	0	0	0
1020	050910205001020	11	4	5	0	0	0	0	2	0
1020	050910204001020	0	0	0	0	0	0	0	0	0
1020	050910206001020	7	2	2	0	2	0	1	0	0
1021	050910206001021	4	1	2	0	0	0	1	0	0
1021	050910205001021	0	0	0	0	0	0	0	0	0
1021	050910204001021	0	0	0	0	0	0	0	0	0
1022	050910205001022	13	0	12	0	0	0	0	1	0
1022	050910204001022	1	0	0	1	0	0	0	0	0
1022	050910206001022	7	0	3	0	0	0	0	4	0
1023	050910206001023	0	0	0	0	0	0	0	0	0
1023	050910205001023	11	2	4	0	1	0	0	4	0
1023	050910204001023	16	9	5	0	0	0	0	1	1
1024	050910204001024	0	0	0	0	0	0	0	0	0
1024	050910205001024	21	4	6	0	0	0	0	8	3

# Redistricting Final Report

## Texarkana City Council Wards

1024	050910206001024	11	0	4	0	0	0	1	6	0
1025	050910206001025	7	1	4	0	0	0	0	2	0
1025	050910204001025	32	27	5	0	0	0	0	0	0
1025	050910205001025	31	15	13	0	0	0	3	0	0
1026	050910205001026	5	0	5	0	0	0	0	0	0
1026	050910206001026	11	2	6	0	0	0	3	0	0
1026	050910204001026	21	2	15	0	0	0	4	0	0
1027	050910205001027	17	5	6	0	0	0	6	0	0
1027	050910206001027	8	1	5	0	0	0	0	2	0
1027	050910204001027	6	3	3	0	0	0	0	0	0
1028	050910204001028	0	0	0	0	0	0	0	0	0
1028	050910206001028	36	0	34	0	0	0	0	2	0
1028	050910205001028	25	2	23	0	0	0	0	0	0
1029	050910204001029	0	0	0	0	0	0	0	0	0
1029	050910205001029	21	8	12	0	0	0	0	1	0
1029	050910206001029	22	1	19	0	0	0	2	0	0
1030	050910206001030	6	0	4	0	0	0	0	2	0
1030	050910205001030	21	5	15	1	0	0	0	0	0
1030	050910204001030	0	0	0	0	0	0	0	0	0
1031	050910204001031	1	0	0	0	1	0	0	0	0
1031	050910206001031	0	0	0	0	0	0	0	0	0
1031	050910205001031	62	6	51	0	0	0	4	1	0
1032	050910206001032	38	0	33	0	0	0	0	5	0
1032	050910204001032	6	2	0	1	0	0	0	3	0
1032	050910205001032	0	0	0	0	0	0	0	0	0
1033	050910205001033	9	7	0	0	0	0	1	1	0
1033	050910204001033	20	3	16	0	0	0	1	0	0
1033	050910206001033	22	1	17	0	0	0	0	4	0
1034	050910204001034	3	1	1	0	0	0	0	0	1
1034	050910205001034	16	2	12	0	0	0	1	1	0
1035	050910205001035	20	12	8	0	0	0	0	0	0
1035	050910204001035	0	0	0	0	0	0	0	0	0
1036	050910205001036	11	7	4	0	0	0	0	0	0
1036	050910204001036	3	0	1	0	0	0	2	0	0
1037	050910205001037	4	0	3	0	0	0	1	0	0
1037	050910204001037	8	5	2	0	0	0	0	0	1
1038	050910204001038	6	3	0	0	0	0	0	3	0
1038	050910205001038	18	6	11	0	1	0	0	0	0
1039	050910205001039	10	9	0	0	0	0	1	0	0
1039	050910204001039	6	2	0	0	0	0	0	4	0
1040	050910205001040	14	5	9	0	0	0	0	0	0
1040	050910204001040	57	16	40	0	0	0	0	1	0
1041	050910205001041	14	11	2	0	0	0	0	1	0
1041	050910204001041	7	6	0	0	0	0	1	0	0
1042	050910205001042	10	3	5	0	0	0	1	1	0
1042	050910204001042	5	3	1	1	0	0	0	0	0
1043	050910205001043	16	3	11	0	0	0	2	0	0
1043	050910204001043	0	0	0	0	0	0	0	0	0
1044	* 050910204001044	0	0	0	0	0	0	0	0	0

## Redistricting Final Report

## Texarkana City Council Wards

1044	050910205001044	1	0	1	0	0	0	0	0	0
1045	050910205001045	16	6	8	0	0	0	0	2	0
1045	050910204001045	2	0	0	0	0	0	2	0	0
1046	050910205001046	13	0	12	0	0	0	1	0	0
1046	050910204001046	0	0	0	0	0	0	0	0	0
1047	050910204001047	45	20	23	0	0	0	0	2	0
1048	050910204001048	6	0	5	0	0	0	0	1	0
1049	050910204001049	100	19	78	0	0	0	2	1	0
1050	050910204001050	0	0	0	0	0	0	0	0	0
1051	050910204001051	0	0	0	0	0	0	0	0	0
1052	050910204001052	0	0	0	0	0	0	0	0	0
1053	050910204001053	0	0	0	0	0	0	0	0	0
1054	050910204001054	7	0	0	0	1	0	1	5	0
1055	050910204001055	0	0	0	0	0	0	0	0	0
1056	050910204001056	0	0	0	0	0	0	0	0	0
1057	050910204001057	0	0	0	0	0	0	0	0	0
1058	050910204001058	0	0	0	0	0	0	0	0	0
1059	050910204001059	5	4	0	0	0	0	1	0	0
1060	050910204001060	0	0	0	0	0	0	0	0	0
1061	050910204001061	0	0	0	0	0	0	0	0	0
1062	050910204001062	0	0	0	0	0	0	0	0	0
1063	050910204001063	0	0	0	0	0	0	0	0	0
1064	050910204001064	0	0	0	0	0	0	0	0	0
1065	050910204001065	0	0	0	0	0	0	0	0	0
1066	050910204001066	0	0	0	0	0	0	0	0	0
1067	050910204001067	0	0	0	0	0	0	0	0	0
1068	050910204001068	0	0	0	0	0	0	0	0	0
1069	050910204001069	0	0	0	0	0	0	0	0	0
1070	050910204001070	0	0	0	0	0	0	0	0	0
1071	050910204001071	0	0	0	0	0	0	0	0	0
1072	050910204001072	0	0	0	0	0	0	0	0	0
1073	050910204001073	0	0	0	0	0	0	0	0	0
1074	050910204001074	0	0	0	0	0	0	0	0	0
1075	050910204001075	15	6	2	0	0	0	5	2	0
1076	050910204001076	11	2	3	0	1	0	1	4	0
1077	050910204001077	0	0	0	0	0	0	0	0	0
1078	050910204001078	0	0	0	0	0	0	0	0	0
1079	050910204001079	20	13	5	0	0	0	1	1	0
1080	050910204001080	18	10	3	4	0	0	1	0	0
1081	050910204001081	35	12	21	0	0	0	2	0	0
1082	050910204001082	25	20	5	0	0	0	0	0	0
1083	050910204001083	12	1	10	0	0	0	0	1	0
1084	050910204001084	5	1	4	0	0	0	0	0	0
1085	050910204001085	0	0	0	0	0	0	0	0	0
1086	050910204001086	2	1	0	0	0	0	0	1	0
1087	050910204001087	7	2	5	0	0	0	0	0	0
1088	050910204001088	8	0	7	0	0	0	1	0	0
1089	050910204001089	11	7	2	0	0	0	0	2	0
1090	050910204001090	19	0	13	0	0	0	5	1	0

## Redistricting Final Report

## Texarkana City Council Wards

1091	050910204001091	13	2	8	0	0	0	2	1	0
1092	050910204001092	14	10	2	0	1	0	1	0	0
1093	050910204001093	11	3	7	0	0	0	1	0	0
1094	050910204001094	5	0	3	0	0	0	2	0	0
1095	050910204001095	10	0	9	0	0	0	1	0	0
1096	050910204001096	18	7	1	0	0	0	10	0	0
2000	050910204002000	16	4	6	0	0	0	4	2	0
2000	050910205002000	16	12	0	0	0	0	1	3	0
2001	050910205002001	33	2	25	0	0	0	6	0	0
2001	050910204002001	11	5	4	0	2	0	0	0	0
2002	050910204002002	28	22	6	0	0	0	0	0	0
2002	050910205002002	13	0	13	0	0	0	0	0	0
2003	050910204002003	18	6	10	0	0	0	1	1	0
2003	050910205002003	9	0	6	0	0	0	0	3	0
2004	050910205002004	8	5	3	0	0	0	0	0	0
2004	050910204002004	27	5	17	0	0	0	5	0	0
2005	050910204002005	8	6	0	0	0	0	2	0	0
2005	050910205002005	2	2	0	0	0	0	0	0	0
2005	050910206002005	197	53	139	0	0	0	2	3	0
2006	050910206002006	5	4	0	0	0	0	0	1	0
2006	050910205002006	8	6	1	0	0	0	1	0	0
2006	050910204002006	17	0	7	3	0	0	6	0	1
2007	050910205002007	20	2	18	0	0	0	0	0	0
2007	050910204002007	21	9	10	0	0	0	2	0	0
2007	050910206002007	10	0	4	0	1	0	5	0	0
2008	050910206002008	4	0	2	0	1	0	1	0	0
2008	050910205002008	15	0	15	0	0	0	0	0	0
2008	050910204002008	16	7	7	0	0	0	2	0	0
2009	050910205002009	20	0	19	0	0	0	0	1	0
2009	050910204002009	23	4	6	0	0	0	13	0	0
2009	050910206002009	11	4	6	0	0	0	0	1	0
2010	050910206002010	14	0	12	0	0	0	0	2	0
2010	050910205002010	30	1	27	0	0	0	1	1	0
2010	050910204002010	5	0	1	0	0	0	1	3	0
2011	050910205002011	11	0	11	0	0	0	0	0	0
2011	050910204002011	10	5	0	0	0	0	4	1	0
2012	050910204002012	12	6	4	0	0	0	2	0	0
2012	050910205002012	17	2	15	0	0	0	0	0	0
2013	050910204002013	25	1	16	0	3	0	2	3	0
2013	050910205002013	24	2	18	0	0	0	4	0	0
2014	050910204002014	40	29	10	0	0	0	1	0	0
2014	050910205002014	26	0	24	0	0	0	0	2	0
2015	050910204002015	29	19	6	0	0	0	4	0	0
2015	050910205002015	6	5	0	0	0	0	0	1	0
2016	050910205002016	8	5	1	0	0	0	2	0	0
2016	050910204002016	15	5	7	0	0	0	3	0	0
2017	050910204002017	29	10	14	0	0	0	5	0	0
2017	050910205002017	9	0	8	0	0	0	1	0	0
2018	050910205002018	4	1	3	0	0	0	0	0	0

## Redistricting Final Report

## Texarkana City Council Wards

2018	050910204002018	25	15	5	0	0	0	5	0	0
2019	050910205002019	13	0	9	0	0	0	3	1	0
2019	050910204002019	41	28	11	0	0	0	2	0	0
2020	050910204002020	155	37	106	0	0	0	5	7	0
2020	050910205002020	8	1	4	0	0	0	0	3	0
2021	050910204002021	36	29	7	0	0	0	0	0	0
2021	050910205002021	12	2	8	0	0	0	0	2	0
2022	050910205002022	16	6	10	0	0	0	0	0	0
2022	050910204002022	16	9	5	0	0	0	1	1	0
2023	050910205002023	0	0	0	0	0	0	0	0	0
2023	050910204002023	7	1	2	0	1	0	1	2	0
2024	050910204002024	13	3	9	0	0	0	1	0	0
2024	050910205002024	0	0	0	0	0	0	0	0	0
2025	050910205002025	5	0	4	0	0	0	0	1	0
2025	050910204002025	17	6	8	0	0	0	2	1	0
2026	050910204002026	5	2	3	0	0	0	0	0	0
2026	050910205002026	9	0	9	0	0	0	0	0	0
2027	050910205002027	6	1	1	0	0	0	4	0	0
2027	050910204002027	17	4	10	0	0	0	1	2	0
2028	050910205002028	18	0	18	0	0	0	0	0	0
2028	050910204002028	5	2	3	0	0	0	0	0	0
2029	050910205002029	1	1	0	0	0	0	0	0	0
2030	050910205002030	16	0	16	0	0	0	0	0	0
2031	050910205002031	19	0	17	0	0	0	1	1	0
2032	050910205002032	2	2	0	0	0	0	0	0	0
2033	050910205002033	8	6	1	0	0	0	0	1	0
2034	050910205002034	33	15	15	0	0	0	0	3	0
2035	050910205002035	6	3	1	0	1	0	0	1	0
2036	050910205002036	0	0	0	0	0	0	0	0	0
2037	050910205002037	0	0	0	0	0	0	0	0	0
2038	050910205002038	6	2	4	0	0	0	0	0	0
2039	050910205002039	0	0	0	0	0	0	0	0	0
2040	050910205002040	54	17	35	0	0	0	2	0	0
2041	050910205002041	4	3	0	0	0	0	1	0	0
2042	050910205002042	6	0	5	0	0	0	0	1	0
2043	050910205002043	6	0	2	0	3	0	0	1	0
2044	050910205002044	32	8	24	0	0	0	0	0	0
2045	050910205002045	4	2	1	0	0	0	1	0	0
2046	050910205002046	4	1	3	0	0	0	0	0	0
2047	050910205002047	7	1	6	0	0	0	0	0	0
2048	050910205002048	7	4	1	0	0	0	2	0	0
2049	050910205002049	8	6	0	0	2	0	0	0	0
2050	050910205002050	16	11	5	0	0	0	0	0	0
2051	050910205002051	11	8	2	0	0	0	1	0	0
2052	050910205002052	11	6	4	0	0	0	1	0	0
2053	050910205002053	12	10	2	0	0	0	0	0	0
2054	050910205002054	9	6	0	0	0	0	3	0	0
2055	050910205002055	28	11	16	0	0	0	1	0	0
2056	050910205002056	15	14	1	0	0	0	0	0	0

## Redistricting Final Report

## Texarkana City Council Wards

2057	050910205002057	13	8	0	0	0	0	0	5	0
2058	050910205002058	1	0	0	0	0	0	0	1	0
2059	050910205002059	18	2	14	0	0	0	0	2	0
2060	050910205002060	14	8	3	0	0	0	3	0	0
2061	050910205002061	8	2	4	0	0	0	2	0	0
2062	050910205002062	11	3	4	0	1	0	3	0	0
2063	050910205002063	24	13	5	0	2	0	1	3	0
2064	050910205002064	21	2	18	0	0	0	0	1	0
2065	050910205002065	26	2	24	0	0	0	0	0	0
2066	050910205002066	81	58	0	0	2	0	0	21	0
2067	050910205002067	0	0	0	0	0	0	0	0	0
2075	050910205002075	38	31	0	0	0	0	2	5	0
2084	050910205002084	136	113	18	0	1	0	0	4	0
2085	050910205002085	5	0	3	0	0	0	2	0	0
2086	050910205002086	15	8	0	0	3	0	4	0	0
2087	050910205002087	13	7	3	0	0	0	3	0	0
2088	050910205002088	25	3	13	0	0	0	6	3	0
2089	050910205002089	20	15	0	0	0	0	4	1	0
2090	050910205002090	12	7	2	0	0	0	0	3	0
2091	050910205002091	16	2	9	0	0	0	2	3	0
2092	050910205002092	9	4	3	0	0	0	2	0	0
2093	050910205002093	14	11	3	0	0	0	0	0	0
2094	050910205002094	10	7	1	0	0	0	1	1	0
2095	050910205002095	8	5	1	0	0	0	1	1	0
2096	050910205002096	25	10	12	0	0	0	1	1	1
2097	050910205002097	19	5	11	0	0	0	2	1	0
2098	050910205002098	1	0	0	0	0	0	1	0	0
2099	050910205002099	23	10	5	0	0	0	4	4	0
2102	050910205002102	6	0	0	0	0	0	4	2	0
2103	050910205002103	17	8	8	0	0	0	1	0	0
2104	050910205002104	15	4	9	0	0	0	2	0	0
3000	050910206003000	28	0	27	0	0	0	1	0	0
3001	050910206003001	13	0	11	0	0	0	0	1	1
3002	050910206003002	0	0	0	0	0	0	0	0	0
3003	050910206003003	4	1	3	0	0	0	0	0	0
3004	050910206003004	21	0	21	0	0	0	0	0	0
3005	050910206003005	16	0	15	0	0	0	0	1	0
3006	050910206003006	8	0	8	0	0	0	0	0	0
3007	050910206003007	6	0	6	0	0	0	0	0	0
3008	050910206003008	93	6	83	0	0	0	4	0	0
3009	050910206003009	4	0	3	0	0	0	0	1	0
3010	050910206003010	49	0	49	0	0	0	0	0	0
3011	050910206003011	5	0	4	0	0	0	1	0	0
3012	050910206003012	5	0	4	0	1	0	0	0	0
3013	050910206003013	11	0	10	0	0	0	1	0	0
3014	050910206003014	15	0	15	0	0	0	0	0	0
3015	050910206003015	95	0	95	0	0	0	0	0	0
3016	050910206003016	234	180	47	0	0	0	0	7	0
3017	050910206003017	16	0	15	0	0	0	1	0	0

# Redistricting Final Report

## Texarkana City Council Wards

3018	050910206003018	10	0	10	0	0	0	0	0	0
3019	050910206003019	31	0	29	0	0	0	0	2	0
3037	050910202003037	0	0	0	0	0	0	0	0	0
3038	050910202003038	0	0	0	0	0	0	0	0	0
3039	050910202003039	8	4	4	0	0	0	0	0	0
3043	050910202003043	13	0	10	0	0	0	2	1	0
3044	050910202003044	3	3	0	0	0	0	0	0	0
3045	050910202003045	0	0	0	0	0	0	0	0	0

### District: 3

Split	Block	Corr. Facil.	Geo ID	Total Population	White	Black	Asian	Native American	Hawaiian Pacific Islander	Hispanic	Multiple	Other
	1000		050910208021000	78	69	2	0	0	0	6	1	0
	1000		050919800001000	32	26	5	0	0	0	1	0	0
	1001		050910208021001	23	9	8	0	0	0	4	2	0
	1001		050919800001001	0	0	0	0	0	0	0	0	0
	1001		050910209021001	7	6	0	0	0	0	0	1	0
	1002		050910209021002	52	52	0	0	0	0	0	0	0
	1002		050910207021002	0	0	0	0	0	0	0	0	0
	1002		050919800001002	0	0	0	0	0	0	0	0	0
	1002		050910208021002	0	0	0	0	0	0	0	0	0
	1003		050910208021003	0	0	0	0	0	0	0	0	0
	1003		050919800001003	0	0	0	0	0	0	0	0	0
	1003		050910207021003	20	6	11	0	0	0	0	2	1
	1003		050910209021003	21	21	0	0	0	0	0	0	0
	1004		050910209021004	37	25	10	0	1	0	0	1	0
	1004		050910208021004	0	0	0	0	0	0	0	0	0
	1004		050910207021004	17	2	15	0	0	0	0	0	0
	1005		050910208021005	213	184	23	4	0	0	0	2	0
	1005		050910209021005	44	41	2	0	0	0	1	0	0
	1006		050910209021006	11	9	0	0	0	0	0	2	0
	1006		050910208021006	0	0	0	0	0	0	0	0	0
	1007		050910209021007	11	10	0	0	0	0	0	1	0
	1007		050910208021007	23	7	14	0	1	0	1	0	0
	1008		050910209021008	23	20	2	0	0	0	1	0	0
	1008		050910208021008	59	38	11	0	0	0	2	8	0
	1009		050910208021009	65	58	0	0	0	0	3	4	0
	1009		050910209021009	0	0	0	0	0	0	0	0	0
	1010		050910209021010	7	4	3	0	0	0	0	0	0
	1013		050910208021013	100	83	15	0	0	0	0	1	1
	1013		050910207021013	0	0	0	0	0	0	0	0	0
	1014		050910208021014	0	0	0	0	0	0	0	0	0
	1015		050910207021015	0	0	0	0	0	0	0	0	0
	1016		050910207021016	0	0	0	0	0	0	0	0	0
	1016		050910209021016	9	5	0	2	0	0	2	0	0
	1017		050910207021017	9	5	1	0	3	0	0	0	0
	1018		050910207021018	0	0	0	0	0	0	0	0	0
	1018		050910202001018	28	17	7	0	0	0	1	3	0



## Redistricting Final Report

## Texarkana City Council Wards

1019	050910202001019	16	15	0	0	0	0	1	0	0
1019	050910207021019	56	0	53	0	0	0	0	3	0
1020	050910207021020	7	0	4	0	0	0	0	3	0
1020	050910202001020	22	15	1	0	0	0	2	4	0
1021	050910207021021	27	6	19	0	1	0	1	0	0
1022	050910207021022	0	0	0	0	0	0	0	0	0
1023	050910207021023	6	2	1	0	0	0	0	3	0
1024	050910207021024	10	5	1	0	0	0	0	4	0
1025	050910207021025	13	3	3	0	0	0	1	5	1
1026	050910207021026	41	12	25	0	0	0	4	0	0
1026	050910202001026	23	6	10	0	1	0	6	0	0
1027	050910207021027	11	0	9	0	0	0	0	2	0
1027	050910202001027	8	6	0	0	0	0	0	2	0
1028	050910202001028	10	7	0	0	0	0	0	3	0
1028	050910207021028	7	0	7	0	0	0	0	0	0
1029	050910202001029	15	6	1	4	0	0	0	4	0
1029	050910207021029	17	0	15	0	0	0	1	1	0
1030	050910207021030	10	2	7	0	0	0	0	1	0
1030	050910202001030	23	15	3	0	0	0	0	4	1
1031	050910207021031	9	1	7	0	0	0	0	1	0
1031	050910202001031	0	0	0	0	0	0	0	0	0
1032	050910202001032	17	9	7	0	0	0	1	0	0
1032	050910207021032	29	1	28	0	0	0	0	0	0
1033	050910202001033	25	16	7	0	0	0	1	1	0
1033	050910207021033	49	2	45	0	0	0	2	0	0
1034	050910209021034	21	19	0	0	0	0	0	2	0
1034	050910202001034	22	22	0	0	0	0	0	0	0
1034	050910207021034	2	0	1	0	0	0	1	0	0
1035	050910207021035	0	0	0	0	0	0	0	0	0
1035	050910202001035	43	21	21	0	0	0	1	0	0
1035	050910209021035	48	41	0	0	3	0	3	1	0
1036	050910202001036	12	9	0	0	0	0	1	2	0
1036	050910207021036	0	0	0	0	0	0	0	0	0
1037	050910202001037	13	5	5	0	0	0	3	0	0
1037	050910207021037	0	0	0	0	0	0	0	0	0
1038	050910207021038	11	0	10	0	0	0	1	0	0
1039	050910207021039	3	0	2	0	0	0	1	0	0
1040	050910207021040	1	0	0	0	1	0	0	0	0
1041	050910207021041	16	4	8	0	0	0	4	0	0
1042	050910207021042	3	0	2	0	0	0	1	0	0
1043	050910207021043	12	2	10	0	0	0	0	0	0
1044	050910207021044	9	2	6	0	0	0	1	0	0
1045	050910207021045	4	0	4	0	0	0	0	0	0
1046	050910207021046	19	0	18	0	0	0	1	0	0
1047	050910207021047	21	4	16	0	0	0	1	0	0
1048	050910207021048	0	0	0	0	0	0	0	0	0
1049	050910207021049	0	0	0	0	0	0	0	0	0
1050	050910207021050	77	60	16	0	0	0	0	1	0
1051	050910207021051	0	0	0	0	0	0	0	0	0

## Redistricting Final Report

## Texarkana City Council Wards

1052	050910207021052	13	2	11	0	0	0	0	0	0
1053	050910209011053	27	25	0	0	0	0	1	1	0
1053	050910207021053	11	1	9	0	0	0	1	0	0
1054	050910207021054	5	1	4	0	0	0	0	0	0
1055	050910207021055	11	0	9	0	0	0	1	1	0
1056	050910207021056	12	3	7	0	0	0	1	1	0
1057	050910207021057	12	1	4	2	0	0	4	1	0
1058	050910207021058	22	0	21	0	0	0	1	0	0
1059	050910207021059	9	6	2	0	0	0	1	0	0
1060	050910207021060	11	1	4	2	1	0	3	0	0
1061	050910207021061	17	0	13	0	0	0	4	0	0
1062	050910207021062	0	0	0	0	0	0	0	0	0
1063	050910207021063	11	0	7	0	1	0	3	0	0
1064	050910207021064	0	0	0	0	0	0	0	0	0
1065	050910207021065	0	0	0	0	0	0	0	0	0
1066	050910207021066	6	4	2	0	0	0	0	0	0
1067	050910207021067	0	0	0	0	0	0	0	0	0
1068	050910207021068	13	3	5	0	2	0	0	3	0
1069	050910207021069	32	4	21	0	0	0	4	2	1
1070	050910207021070	25	0	23	0	0	0	2	0	0
1071	050910207021071	5	2	3	0	0	0	0	0	0
1072	050910207021072	4	0	3	0	0	0	0	1	0
1073	050910207021073	0	0	0	0	0	0	0	0	0
2000	050910202002000	21	11	9	0	0	0	1	0	0
2000	050910206002000	393	55	319	0	0	0	7	12	0
2001	050910206002001	40	19	19	0	0	0	1	1	0
2001	050910202002001	19	13	3	0	0	0	1	2	0
2001	050910208012001	8	0	3	0	0	0	5	0	0
2002	050910208012002	36	26	0	0	1	0	2	5	2
2002	050910206002002	131	21	95	0	0	0	3	12	0
2002	050910202002002	6	4	1	0	0	0	1	0	0
2003	050910207012003	24	0	18	0	0	0	5	1	0
2003	050910208012003	0	0	0	0	0	0	0	0	0
2003	050910206002003	227	28	188	0	1	0	3	7	0
2003	050910202002003	10	4	6	0	0	0	0	0	0
2004	050910206002004	36	0	35	0	0	0	1	0	0
2004	050910202002004	28	21	1	0	0	0	2	4	0
2005	050910202002005	25	17	3	0	0	0	1	4	0
2006	050910202002006	15	13	1	0	0	0	0	1	0
2007	050910202002007	13	6	6	0	0	0	1	0	0
2008	050910202002008	13	9	1	0	0	0	0	3	0
2009	050910202002009	21	9	10	0	0	0	0	2	0
2009	050910207012009	78	8	63	0	0	0	7	0	0
2010	050910207012010	60	5	42	3	0	0	6	2	2
2010	050910209012010	10	8	2	0	0	0	0	0	0
2010	050910202002010	18	10	6	0	0	0	1	1	0
2011	050910209012011	8	1	3	0	0	0	0	4	0
2011	050910202002011	26	6	17	0	0	0	0	3	0
2012	050910202002012	9	2	5	0	0	0	1	1	0

# Redistricting Final Report

## Texarkana City Council Wards

2013	050910202002013	20	10	6	0	0	0	2	2	0
2014	050910202002014	26	22	4	0	0	0	0	0	0
2015	050910202002015	21	13	6	0	0	0	0	2	0
2016	050910202002016	29	18	9	0	0	0	0	2	0
2017	050910202002017	9	5	4	0	0	0	0	0	0
2018	050910202002018	23	16	7	0	0	0	0	0	0
2019	050910202002019	21	11	0	0	0	0	10	0	0
2020	050910202002020	15	11	2	0	0	0	0	2	0
2021	050910202002021	19	11	7	0	0	0	0	1	0
2022	050910202002022	9	4	3	0	0	0	0	2	0
2023	050910202002023	22	11	3	2	0	0	4	2	0
2023	050910208012023	0	0	0	0	0	0	0	0	0
2024	050910208012024	221	62	141	0	0	0	6	12	0
2024	050910202002024	26	15	10	0	0	0	1	0	0
2025	050910208012025	0	0	0	0	0	0	0	0	0
2025	050910202002025	17	4	9	0	0	0	3	1	0
2026	050910202002026	23	14	9	0	0	0	0	0	0
2026	050910208012026	0	0	0	0	0	0	0	0	0
2027	050910202002027	11	5	5	0	0	0	0	1	0
2027	050910208012027	0	0	0	0	0	0	0	0	0
2028	050910208012028	0	0	0	0	0	0	0	0	0
2028	050910202002028	24	5	18	0	0	0	1	0	0
2029	050910202002029	15	8	6	0	0	0	0	1	0
2029	050910208012029	1	1	0	0	0	0	0	0	0
2030	050910202002030	11	9	0	0	1	0	0	1	0
2031	050910202002031	6	4	1	0	0	0	0	0	1
2032	050910202002032	19	11	7	0	0	0	0	1	0
2033	050910202002033	11	9	0	0	0	0	2	0	0
2034	050910208012034	0	0	0	0	0	0	0	0	0
2034	050910202002034	85	20	62	0	0	0	0	0	3
2035	050910208012035	24	13	6	0	0	0	0	4	1
2035	050910202002035	9	5	2	2	0	0	0	0	0
2036	050910202002036	14	13	0	0	0	0	0	1	0
2036	050910208012036	11	2	4	0	1	0	2	2	0
2037	050910202002037	6	1	1	0	0	0	3	1	0
2038	050910202002038	11	0	10	0	1	0	0	0	0
2038	050910208012038	0	0	0	0	0	0	0	0	0
2039	050910208012039	0	0	0	0	0	0	0	0	0
2039	050910202002039	22	16	5	0	0	0	1	0	0
2040	050910202002040	33	8	23	0	0	0	2	0	0
2041	050910202002041	7	4	1	2	0	0	0	0	0
2042	050910202002042	0	0	0	0	0	0	0	0	0
2043	050910202002043	0	0	0	0	0	0	0	0	0
2044	050910202002044	0	0	0	0	0	0	0	0	0
2045	050910202002045	10	8	0	0	0	0	0	2	0
2046	050910209012046	6	0	0	0	0	0	6	0	0
3000	050910202003000	5	2	1	0	0	0	2	0	0
3001	050910202003001	14	1	13	0	0	0	0	0	0
3002	050910202003002	0	0	0	0	0	0	0	0	0

## Redistricting Final Report

## Texarkana City Council Wards

3003	050910202003003	2	0	2	0	0	0	0	0	0
3004	050910202003004	26	18	8	0	0	0	0	0	0
3005	050910202003005	11	0	9	0	0	0	0	2	0
3006	050910202003006	2	2	0	0	0	0	0	0	0
3007	050910202003007	4	0	4	0	0	0	0	0	0
3008	050910202003008	6	1	5	0	0	0	0	0	0
3009	050910202003009	4	3	1	0	0	0	0	0	0
3010	050910202003010	8	3	4	0	0	0	1	0	0
3011	050910202003011	1	0	1	0	0	0	0	0	0
3012	050910202003012	17	3	12	0	0	0	2	0	0
3013	050910202003013	16	3	13	0	0	0	0	0	0
3014	050910202003014	9	0	8	1	0	0	0	0	0
3015	050910202003015	8	0	8	0	0	0	0	0	0
3016	050910202003016	14	5	9	0	0	0	0	0	0
3017	050910202003017	11	1	9	0	0	0	0	1	0
3018	050910202003018	8	1	6	0	0	0	0	1	0
3019	050910202003019	4	3	0	1	0	0	0	0	0
3020	050910202003020	11	7	4	0	0	0	0	0	0
3021	050910202003021	9	1	8	0	0	0	0	0	0
3022	050910202003022	11	8	0	1	0	0	2	0	0
3023	050910202003023	20	4	16	0	0	0	0	0	0
3024	050910202003024	22	0	22	0	0	0	0	0	0
3025	050910202003025	35	3	32	0	0	0	0	0	0
3026	050910202003026	8	0	6	0	0	0	0	2	0
3027	050910202003027	4	0	4	0	0	0	0	0	0
3028	050910202003028	0	0	0	0	0	0	0	0	0
3029	050910202003029	6	0	6	0	0	0	0	0	0
3030	050910202003030	0	0	0	0	0	0	0	0	0
3031	050910202003031	25	6	15	0	0	0	0	4	0
3032	050910202003032	26	8	18	0	0	0	0	0	0
3033	050910202003033	9	5	3	0	0	0	0	1	0
3034	050910202003034	15	9	4	0	0	0	0	2	0
3035	050910202003035	1	1	0	0	0	0	0	0	0
3036	050910202003036	15	5	8	0	0	0	2	0	0
3040	050910202003040	2	0	0	0	0	0	2	0	0
3041	050910202003041	0	0	0	0	0	0	0	0	0
3042	050910202003042	8	0	8	0	0	0	0	0	0
3046	050910202003046	1	0	1	0	0	0	0	0	0
4035	050910202004035	11	0	9	0	0	0	1	1	0
4036	050910202004036	22	9	10	2	0	0	1	0	0
4037	050910202004037	5	2	2	0	0	0	1	0	0
4038	050910202004038	16	10	1	0	0	0	5	0	0
4039	050910202004039	18	14	1	0	0	0	0	1	2
4040	050910202004040	19	15	1	0	0	0	3	0	0
4041	050910202004041	20	13	5	0	0	0	1	0	1
4043	050910202004043	17	14	0	0	0	0	3	0	0
4044	050910202004044	11	8	3	0	0	0	0	0	0
4045	050910202004045	22	10	11	0	0	0	0	1	0
4046	050910202004046	12	5	3	0	0	0	4	0	0

# Redistricting Final Report

## Texarkana City Council Wards

4047	050910202004047	15	12	0	0	0	0	2	0	1
4048	050910202004048	14	8	2	0	0	0	0	4	0
4049	050910202004049	0	0	0	0	0	0	0	0	0
4050	050910202004050	7	0	4	0	0	0	1	2	0
4051	050910202004051	7	6	0	0	0	0	0	1	0
4052	050910202004052	9	4	1	0	0	0	0	4	0
4053	050910202004053	11	6	2	0	2	0	1	0	0
4054	050910202004054	16	3	6	0	0	0	6	0	1
4055	050910202004055	5	1	4	0	0	0	0	0	0
4056	050910202004056	10	9	0	0	0	0	1	0	0

### District: 4

Split	Block	Corr. Facil.	Geo ID	Total Population	White	Black	Asian	Native American	Hawaiian Pacific Islander	Hispanic	Multiple	Other
	1000		050910202001000	24	13	6	0	1	0	4	0	0
	1001		050910202001001	26	8	14	0	0	0	4	0	0
	1001		050910201001001	0	0	0	0	0	0	0	0	0
	1002		050910202001002	33	16	12	0	1	0	3	1	0
	1002		050910201001002	0	0	0	0	0	0	0	0	0
	1003		050910202001003	40	24	10	3	0	0	1	2	0
	1003		050910201001003	414	192	187	0	1	0	6	28	0
	1004		050910202001004	15	10	5	0	0	0	0	0	0
	1004		050910201001004	44	36	4	0	0	0	3	1	0
	1005		050910201001005	75	55	17	2	0	0	1	0	0
	1005		050910202001005	35	26	8	1	0	0	0	0	0
	1006		050910202001006	38	23	15	0	0	0	0	0	0
	1006		050910201001006	0	0	0	0	0	0	0	0	0
	1007		050910201001007	20	3	10	0	0	0	1	6	0
	1007		050910202001007	19	11	1	1	0	0	4	2	0
	1008		050910201001008	6	1	0	0	0	0	1	4	0
	1008		050910202001008	11	2	6	1	0	0	0	2	0
	1009		050910201001009	93	58	31	2	0	0	0	2	0
	1009		050910202001009	16	12	3	0	0	0	1	0	0
	1010		050910201001010	14	4	0	3	0	0	7	0	0
	1010		050910202001010	20	14	5	0	0	0	0	1	0
	1011		050910202001011	26	8	13	0	1	0	2	2	0
	1011		050910201001011	625	214	391	1	3	0	7	9	0
	1012		050910202001012	32	13	12	4	0	0	3	0	0
	1012		050910201001012	12	5	0	3	0	0	0	4	0
	1013		050910201001013	31	24	0	0	0	0	0	7	0
	1013		050910202001013	15	11	0	0	0	0	3	1	0
	1014		050910201001014	9	2	4	0	0	0	3	0	0
	1014		050910202001014	1	0	0	0	1	0	0	0	0
	1015		050910201001015	2	1	0	0	0	0	0	1	0
	1015		050910202001015	20	12	6	0	0	0	0	2	0
	1016		050910202001016	5	0	3	0	0	0	2	0	0
	1016		050910201001016	0	0	0	0	0	0	0	0	0
	1017		050910202001017	28	19	5	0	0	0	3	1	0

## Redistricting Final Report

## Texarkana City Council Wards

1017	050910201001017	0	0	0	0	0	0	0	0	0
1018	050910201001018	0	0	0	0	0	0	0	0	0
1019	050910201001019	10	4	2	0	0	0	4	0	0
1020	050910201001020	0	0	0	0	0	0	0	0	0
1021	050910201001021	0	0	0	0	0	0	0	0	0
1021	050910202001021	26	7	14	0	0	0	0	4	1
1022	050910201001022	46	23	16	3	0	0	2	2	0
1022	050910202001022	8	6	0	0	0	0	0	2	0
1023	050910202001023	28	13	11	2	0	0	0	2	0
1023	050910201001023	24	9	13	0	0	0	2	0	0
1024	050910202001024	81	30	49	1	0	0	0	1	0
1024	050910201001024	19	16	3	0	0	0	0	0	0
1025	050910201001025	20	8	3	3	0	0	2	4	0
1025	050910202001025	13	8	2	0	0	0	0	3	0
1026	050910201001026	18	9	6	0	0	0	3	0	0
1027	050910201001027	4	1	0	0	0	0	1	2	0
1028	050910201001028	23	15	6	0	0	0	0	2	0
1029	050910201001029	16	10	0	0	1	0	3	2	0
1030	050910201001030	14	6	0	0	3	0	3	2	0
2000	050910201002000	24	7	11	0	0	0	3	3	0
2001	050910201002001	97	23	69	0	0	0	3	1	1
2002	050910201002002	12	2	10	0	0	0	0	0	0
2003	050910201002003	14	7	3	1	0	0	3	0	0
2004	050910201002004	16	16	0	0	0	0	0	0	0
2005	050910201002005	6	3	1	0	0	0	0	2	0
2006	050910201002006	21	4	13	0	0	0	2	2	0
2007	050910201002007	19	12	3	0	0	0	3	1	0
2008	050910201002008	17	12	2	0	0	0	0	3	0
2009	050910201002009	10	6	1	0	0	0	2	1	0
2010	050910201002010	6	4	2	0	0	0	0	0	0
2011	050910201002011	8	4	1	0	0	0	1	2	0
2012	050910201002012	25	14	6	0	1	0	1	3	0
2013	050910201002013	21	3	16	0	0	0	2	0	0
2014	050910201002014	16	8	7	0	0	0	0	1	0
2015	050910201002015	38	20	16	0	0	0	0	2	0
2016	050910201002016	18	7	7	0	0	0	3	1	0
2017	050910201002017	16	8	6	0	1	0	0	1	0
2018	050910201002018	0	0	0	0	0	0	0	0	0
2019	050910201002019	48	15	27	0	0	0	4	2	0
2020	050910201002020	43	7	32	0	0	0	0	4	0
2021	050910201002021	31	14	9	0	2	0	2	4	0
2022	050910201002022	108	40	62	0	0	0	6	0	0
2023	050910201002023	119	70	48	0	0	0	1	0	0
2024	050910201002024	24	14	8	0	0	0	1	1	0
2025	050910201002025	16	14	0	0	0	0	0	2	0
2026	050910201002026	32	23	9	0	0	0	0	0	0
2027	050910201002027	4	0	2	0	0	0	2	0	0
2028	050910201002028	42	32	9	0	0	0	1	0	0
2029	050910201002029	42	31	7	0	0	0	0	4	0

# Redistricting Final Report

## Texarkana City Council Wards

2030	050910201002030	38	27	9	0	0	0	0	2	0
2031	050910201002031	28	19	3	0	0	0	1	5	0
2032	050910201002032	45	22	16	0	1	0	5	1	0
2033	050910201002033	30	21	9	0	0	0	0	0	0
2034	050910201002034	26	15	11	0	0	0	0	0	0
2035	050910201002035	17	2	13	0	0	0	0	2	0
2036	050910201002036	0	0	0	0	0	0	0	0	0
2037	050910201002037	3	1	2	0	0	0	0	0	0
2038	050910201002038	13	9	4	0	0	0	0	0	0
2039	050910201002039	23	18	4	0	0	0	0	1	0
3000	050910201003000	18	14	0	0	0	0	4	0	0
3001	050910201003001	9	8	1	0	0	0	0	0	0
3002	050910201003002	14	13	1	0	0	0	0	0	0
3003	050910201003003	13	6	3	0	0	0	0	4	0
3004	050910201003004	10	7	3	0	0	0	0	0	0
3005	050910201003005	19	10	9	0	0	0	0	0	0
3006	050910201003006	16	13	3	0	0	0	0	0	0
3007	050910201003007	14	9	3	0	0	0	0	2	0
3008	050910201003008	29	15	13	0	0	0	1	0	0
3009	050910201003009	15	12	3	0	0	0	0	0	0
3010	050910201003010	23	17	5	0	0	0	0	1	0
3011	050910201003011	11	7	2	0	0	0	0	2	0
3012	050910201003012	19	12	7	0	0	0	0	0	0
3013	050910201003013	4	1	2	0	0	0	0	1	0
3014	050910201003014	23	6	8	0	0	0	2	7	0
3015	050910201003015	15	8	6	0	0	0	0	1	0
3016	050910201003016	21	16	4	0	0	0	1	0	0
3017	050910201003017	9	9	0	0	0	0	0	0	0
3018	050910201003018	21	11	2	0	0	0	1	7	0
3019	050910201003019	22	15	6	0	0	0	0	1	0
3020	050910201003020	17	9	7	0	0	0	0	1	0
3021	050910201003021	6	4	0	0	0	0	0	2	0
3022	050910201003022	17	11	6	0	0	0	0	0	0
3023	050910201003023	17	12	4	0	0	0	1	0	0
3024	050910201003024	2	0	0	0	0	0	0	2	0
3025	050910201003025	15	9	3	0	0	0	0	3	0
3026	050910201003026	11	8	0	0	0	0	0	3	0
3027	050910201003027	10	10	0	0	0	0	0	0	0
3028	050910201003028	23	6	12	5	0	0	0	0	0
3029	050910201003029	7	6	0	0	0	0	0	1	0
3030	050910201003030	7	5	0	0	0	0	1	1	0
3031	050910201003031	24	20	4	0	0	0	0	0	0
3032	050910201003032	20	8	9	1	0	0	1	1	0
3033	050910201003033	18	14	3	0	0	0	0	1	0
3034	050910201003034	12	5	5	0	0	0	1	1	0
3035	050910201003035	22	16	1	0	0	0	2	3	0
3036	050910201003036	20	13	6	0	0	0	0	0	1
3037	050910201003037	9	6	1	0	0	0	1	1	0
4000	050910201004000	91	41	47	0	0	0	1	2	0

## Redistricting Final Report

## Texarkana City Council Wards

4000	050910202004000	21	18	3	0	0	0	0	0	0
4001	050910201004001	33	14	11	0	0	0	8	0	0
4001	050910202004001	18	18	0	0	0	0	0	0	0
4002	050910202004002	7	1	6	0	0	0	0	0	0
4002	050910201004002	45	37	7	0	0	0	0	1	0
4003	050910202004003	10	10	0	0	0	0	0	0	0
4003	050910201004003	19	9	2	1	0	0	3	4	0
4004	050910201004004	36	22	7	0	0	0	3	4	0
4004	050910202004004	10	6	1	0	0	0	2	1	0
4005	050910201004005	23	17	3	0	0	0	0	3	0
4005	050910202004005	13	13	0	0	0	0	0	0	0
4006	050910201004006	3	0	2	0	0	0	0	1	0
4006	050910202004006	6	4	0	0	0	0	2	0	0
4007	050910201004007	31	12	9	0	0	0	0	10	0
4007	050910202004007	4	1	3	0	0	0	0	0	0
4008	050910202004008	17	11	0	0	0	0	0	6	0
4008	050910201004008	23	12	11	0	0	0	0	0	0
4009	050910201004009	34	8	19	0	0	0	6	1	0
4009	050910202004009	8	5	0	0	0	0	0	3	0
4010	050910202004010	30	21	4	0	0	0	1	4	0
4010	050910201004010	0	0	0	0	0	0	0	0	0
4011	050910201004011	16	1	10	0	0	0	3	2	0
4011	050910202004011	9	6	2	0	1	0	0	0	0
4012	050910202004012	19	7	12	0	0	0	0	0	0
4012	050910201004012	30	7	23	0	0	0	0	0	0
4013	050910201004013	40	19	13	0	0	0	5	2	1
4013	050910202004013	11	8	3	0	0	0	0	0	0
4014	050910202004014	8	5	1	0	0	0	2	0	0
4014	050910201004014	81	39	38	0	0	0	3	1	0
4015	050910201004015	27	17	6	0	0	0	2	2	0
4015	050910202004015	7	0	5	0	0	0	0	2	0
4016	050910202004016	17	15	1	0	0	0	0	1	0
4016	050910201004016	32	25	6	0	0	0	0	1	0
4017	050910201004017	15	8	6	0	0	0	1	0	0
4017	050910202004017	19	13	5	0	0	0	0	1	0
4018	050910201004018	11	6	3	0	0	0	1	1	0
4018	050910202004018	6	0	4	0	0	0	2	0	0
4019	050910202004019	9	8	0	0	0	0	0	1	0
4019	050910201004019	11	6	2	0	0	0	2	1	0
4020	050910201004020	14	9	3	0	0	0	1	1	0
4020	050910202004020	20	6	5	0	0	0	5	4	0
4021	050910202004021	11	8	3	0	0	0	0	0	0
4021	050910201004021	12	5	3	1	0	0	1	2	0
4022	050910202004022	8	8	0	0	0	0	0	0	0
4023	050910202004023	2	2	0	0	0	0	0	0	0
4024	050910202004024	13	11	2	0	0	0	0	0	0
4025	050910202004025	4	1	0	1	0	0	0	2	0
4026	050910202004026	6	2	2	0	0	0	2	0	0
4027	050910202004027	11	9	2	0	0	0	0	0	0



# Redistricting Final Report

## Texarkana City Council Wards

4028	050910202004028	2	1	0	0	0	0	1	0	0
4029	050910202004029	1	0	0	0	0	0	0	1	0
4030	050910202004030	15	5	4	0	1	0	2	3	0
4031	050910202004031	11	9	0	0	2	0	0	0	0
4032	050910202004032	16	16	0	0	0	0	0	0	0
4033	050910202004033	21	18	2	0	0	0	1	0	0
4034	050910202004034	14	5	4	0	1	0	2	2	0
4042	050910202004042	12	8	0	0	0	0	4	0	0

### District: 5

Split	Block	Corr. Facil.	Geo ID	Total Population	White	Black	Asian	Native American	Hawaiian Pacific Islander	Hispanic	Multiple	Other
	1000		050910207021000	9	7	0	0	0	0	2	0	0
	1001		050910207021001	104	91	6	0	0	0	7	0	0
	1005		050910207021005	264	113	151	0	0	0	0	0	0
	1006		050910207021006	70	48	21	0	1	0	0	0	0
	1007		050910207021007	17	15	0	0	0	0	0	2	0
	1008		050910207021008	101	12	82	1	2	0	2	2	0
	1009		050910207021009	81	17	64	0	0	0	0	0	0
	1010		050910207021010	177	127	41	0	0	0	5	4	0
	1011		050910207021011	47	23	19	0	0	0	0	5	0
	1012		050910207021012	12	8	0	0	0	0	1	3	0
	1014		050910207021014	53	32	16	3	0	0	0	2	0
	1019		050910207011019	44	30	5	0	0	0	3	2	4
	1020		050910207011020	80	59	19	0	0	0	0	2	0
	1021		050910207011021	97	72	19	0	0	0	2	2	2
	1022		050910207011022	198	154	36	2	1	0	2	3	0
	1026		050910207011026	20	9	9	0	0	0	1	1	0
	1027		050910207011027	22	20	0	0	0	0	2	0	0
	2000		050910207022000	45	30	10	0	1	0	1	3	0
	2001		050910207022001	99	86	9	0	1	0	3	0	0
	2002		050910207022002	58	53	3	0	0	0	1	1	0
	2003		050910207022003	537	187	329	0	0	0	7	14	0
	2004		050910207022004	92	42	38	0	0	0	4	8	0
	2004		050910207012004	355	299	49	0	0	0	1	6	0
	2005		050910207022005	50	36	6	0	0	0	8	0	0
	2005		050910207012005	28	22	2	1	0	0	2	1	0
	2006		050910207012006	24	16	0	0	1	0	5	2	0
	2006		050910207022006	21	11	7	0	0	0	0	3	0
	2007		050910207022007	57	22	26	1	0	0	0	8	0
	2007		050910207012007	34	20	10	1	0	0	0	3	0
	2008		050910207022008	26	9	6	3	0	0	4	4	0
	2008		050910207012008	77	61	3	0	1	0	6	6	0
	2009		050910207022009	40	23	8	0	0	0	5	4	0
	2010		050910207022010	24	3	18	0	2	0	1	0	0
	2011		050910207022011	285	166	106	3	1	0	6	3	0
	2011		050910207012011	111	62	30	1	1	0	3	14	0
	2012		050910207012012	39	28	11	0	0	0	0	0	0

# Redistricting Final Report

## Texarkana City Council Wards

2012	050910207022012	28	18	0	0	2	0	3	5	0
2013	050910207012013	61	29	23	0	1	0	4	4	0
2013	050910207022013	63	45	15	0	0	0	1	0	2
2014	050910207022014	547	269	237	2	3	0	31	2	3
2014	050910207012014	36	23	6	0	0	0	0	6	1
2015	050910207012015	44	34	5	0	0	0	4	1	0
2016	050910207012016	20	13	3	0	0	0	1	3	0
2017	050910207012017	40	28	3	0	0	0	3	6	0
2018	050910207012018	42	24	18	0	0	0	0	0	0
2019	050910207012019	15	3	8	0	0	0	1	1	2
2020	050910207012020	200	49	141	0	0	0	5	5	0
2021	050910207012021	322	133	172	0	0	0	6	11	0
2022	050910207012022	40	23	7	0	5	0	4	1	0
2023	050910207012023	34	12	20	0	0	0	1	1	0
2024	050910207012024	41	17	14	0	0	0	6	4	0

### District: 6

Split	Block	Corr. Facil.	Geo ID	Total Population	White	Black	Asian	Native American	Hawaiian Pacific Islander	Hispanic	Multiple	Other
	1000		050910208011000	68	67	0	0	0	0	0	1	0
	1000		050910201001000	0	0	0	0	0	0	0	0	0
	1000		050910207011000	0	0	0	0	0	0	0	0	0
	1001		050910207011001	112	62	47	0	0	0	3	0	0
	1001		050910208011001	469	361	98	0	1	0	1	8	0
	1002		050910208011002	45	14	23	1	0	0	2	5	0
	1002		050910207011002	36	15	21	0	0	0	0	0	0
	1003		050910207011003	25	0	19	0	0	0	0	6	0
	1003		050910208011003	21	10	9	0	0	0	1	1	0
	1004		050910207011004	37	27	8	0	0	0	0	2	0
	1004		050910208011004	12	6	1	0	0	0	2	0	3
	1005		050910207011005	40	27	12	0	0	0	1	0	0
	1005		050910208011005	36	24	5	2	0	0	5	0	0
	1006		050910208011006	68	43	14	10	0	0	1	0	0
	1006		050910207011006	24	20	3	0	1	0	0	0	0
	1007		050910207011007	42	29	9	0	0	0	3	1	0
	1007		050910208011007	72	51	7	6	0	0	7	1	0
	1008		050910208011008	8	6	0	0	0	0	0	2	0
	1008		050910207011008	43	19	21	0	1	0	2	0	0
	1009		050910208011009	140	98	31	3	0	0	5	3	0
	1009		050910207011009	35	31	2	0	0	0	1	0	1
	1010		050910207011010	108	69	35	0	0	0	2	2	0
	1010		050910208011010	9	0	1	5	2	0	1	0	0
	1011		050910207011011	0	0	0	0	0	0	0	0	0
	1011		050910208011011	12	0	1	2	0	0	7	2	0
	1012		050910207011012	0	0	0	0	0	0	0	0	0
	1012		050910208011012	627	279	294	6	5	0	20	21	2
	1013		050910208011013	32	17	7	5	0	0	1	2	0
	1013		050910207011013	60	24	31	0	1	0	2	2	0

## Redistricting Final Report

## Texarkana City Council Wards

1014	050910207011014	200	134	59	2	1	0	1	3	0
1014	050910208011014	0	0	0	0	0	0	0	0	0
1015	050910208011015	24	8	10	0	0	0	1	5	0
1015	050910207011015	12	4	1	0	1	0	0	1	5
1016	050910207011016	166	98	48	7	0	0	9	4	0
1016	050910208011016	159	128	19	0	0	0	8	4	0
1017	050910208011017	37	21	10	2	0	0	3	1	0
1017	050910207011017	24	12	8	0	0	0	4	0	0
1018	050910208011018	27	15	1	0	0	0	4	7	0
1018	050910207011018	151	70	79	0	0	0	0	2	0
1019	050910208011019	15	11	1	0	0	0	1	2	0
1020	050910208011020	19	9	9	0	0	0	0	1	0
1021	050910208011021	25	17	3	0	0	0	0	0	5
1022	050910208011022	55	42	12	0	0	0	1	0	0
1023	050910208011023	28	18	2	0	0	0	2	6	0
1023	050910207011023	37	18	11	0	0	0	2	6	0
1024	050910208011024	54	53	1	0	0	0	0	0	0
1024	050910207011024	50	36	5	0	0	0	2	7	0
1025	050910207011025	24	16	2	0	0	0	0	3	3
1025	050910208011025	20	12	7	0	0	0	1	0	0
1026	050910208011026	0	0	0	0	0	0	0	0	0
1027	050910208011027	0	0	0	0	0	0	0	0	0
1028	050910207011028	38	23	14	0	1	0	0	0	0
1028	050910208011028	122	65	51	0	0	0	0	0	6
1230	050910209011230	0	0	0	0	0	0	0	0	0
1231	050910209011231	0	0	0	0	0	0	0	0	0
1233	050910209011233	0	0	0	0	0	0	0	0	0
1236	050910209011236	0	0	0	0	0	0	0	0	0
1256	050910209011256	0	0	0	0	0	0	0	0	0
1257	050910209011257	0	0	0	0	0	0	0	0	0
1258	050910209011258	0	0	0	0	0	0	0	0	0
1259	050910209011259	0	0	0	0	0	0	0	0	0
1260	050910209011260	0	0	0	0	0	0	0	0	0
1264	050910209011264	0	0	0	0	0	0	0	0	0
1265	050910209011265	0	0	0	0	0	0	0	0	0
1269	050910209011269	5	4	0	0	0	0	1	0	0
1274	050910209011274	7	0	0	0	3	0	2	2	0
1275	050910209011275	4	3	0	0	0	0	0	1	0
1276	050910209011276	11	7	2	0	1	0	1	0	0
1280	050910209011280	103	91	8	2	0	0	0	2	0
1281	050910209011281	23	20	1	0	0	0	2	0	0
1282	050910209011282	7	2	4	1	0	0	0	0	0
1283	050910209011283	97	78	3	3	1	0	8	4	0
1284	050910209011284	11	9	2	0	0	0	0	0	0
1285	050910209011285	20	18	2	0	0	0	0	0	0
2000	050910207012000	26	1	22	0	0	0	0	2	1
2000	050910208012000	33	17	9	0	2	0	0	5	0
2001	050910207012001	58	38	17	1	0	0	0	2	0
2002	050910207012002	0	0	0	0	0	0	0	0	0

## Redistricting Final Report

## Texarkana City Council Wards

2004	050910208012004	0	0	0	0	0	0	0	0	0
2005	050910208012005	81	62	12	0	0	0	0	6	1
2006	050910208012006	11	4	5	0	0	0	0	2	0
2007	050910208012007	35	27	4	0	1	0	0	3	0
2008	050910208012008	41	19	21	0	0	0	0	1	0
2009	050910208012009	0	0	0	0	0	0	0	0	0
2010	050910208012010	15	10	2	0	0	0	1	2	0
2011	050910208012011	154	142	8	0	2	0	1	1	0
2012	050910208012012	18	9	2	0	1	0	2	2	2
2013	050910208012013	0	0	0	0	0	0	0	0	0
2014	050910208012014	16	12	3	0	0	0	1	0	0
2015	050910208012015	0	0	0	0	0	0	0	0	0
2016	050910208012016	0	0	0	0	0	0	0	0	0
2017	050910208012017	0	0	0	0	0	0	0	0	0
2018	050910208012018	0	0	0	0	0	0	0	0	0
2019	050910208012019	0	0	0	0	0	0	0	0	0
2020	050910208012020	6	0	3	0	1	0	0	1	1
2021	050910208012021	0	0	0	0	0	0	0	0	0
2021	050910209012021	47	36	4	0	0	0	1	2	4
2022	050910208012022	0	0	0	0	0	0	0	0	0
2023	050910209012023	0	0	0	0	0	0	0	0	0
2024	050910209012024	0	0	0	0	0	0	0	0	0
2030	050910209012030	0	0	0	0	0	0	0	0	0
2031	050910209012031	12	9	2	0	0	0	0	1	0
2032	050910209012032	18	5	5	0	0	0	4	4	0
2032	050910208012032	0	0	0	0	0	0	0	0	0
2033	050910208012033	0	0	0	0	0	0	0	0	0
2033	050910209012033	0	0	0	0	0	0	0	0	0
2034	050910209012034	176	160	10	3	0	0	0	2	1
2035	050910209012035	38	32	0	0	0	0	0	3	3
2036	050910209012036	92	72	11	0	0	0	8	0	1
2038	050910209012038	201	167	30	0	0	0	3	1	0
2039	050910209012039	54	42	2	0	0	0	3	7	0
2043	050910209012043	15	9	6	0	0	0	0	0	0

# Redistricting Final Report

Texarkana City Council Wards

## District Maps

### Overview

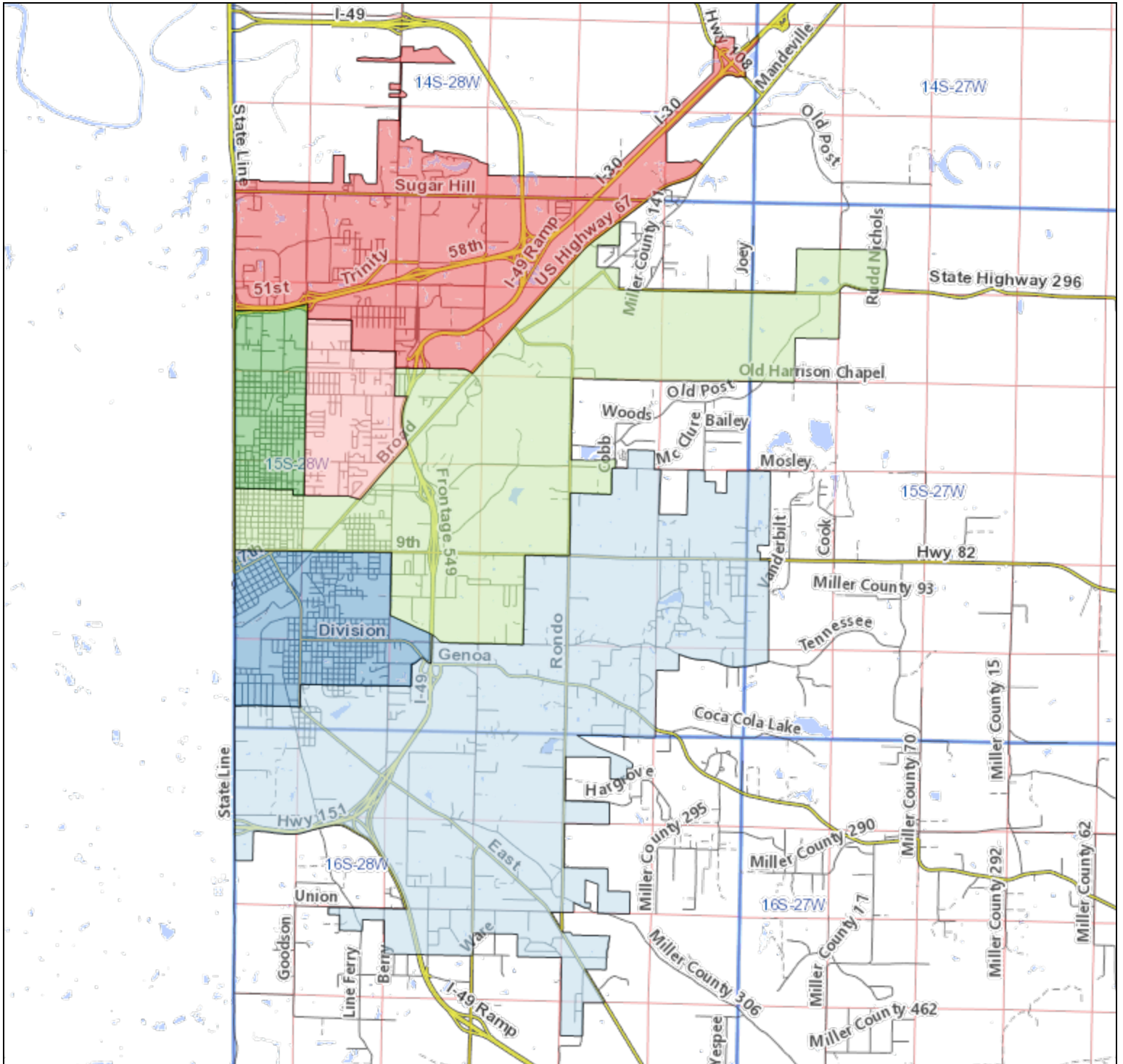

# Redistricting Final Report

Texarkana City Council Wards

District: 1

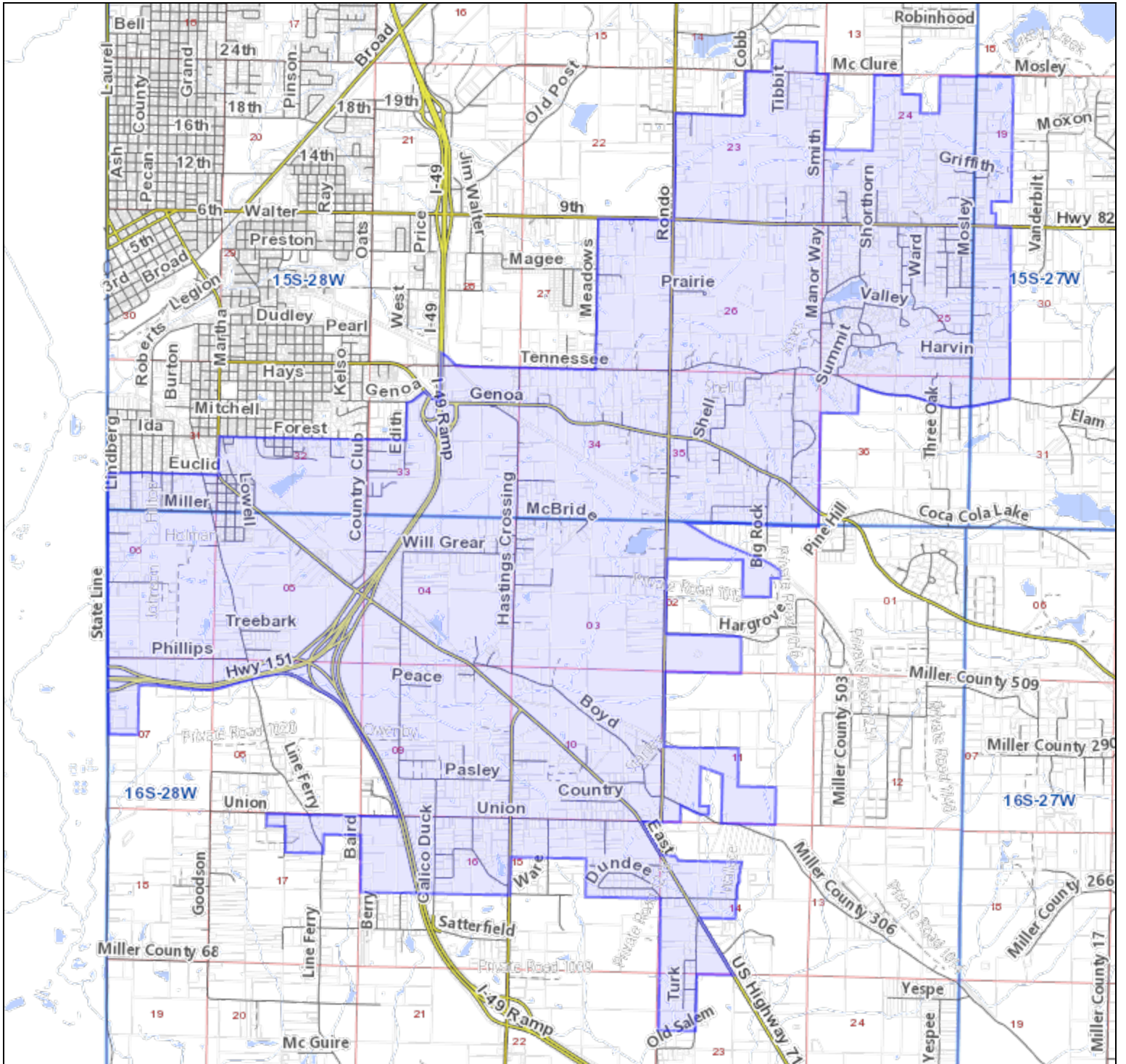

# Redistricting Final Report

Texarkana City Council Wards

## District: 2

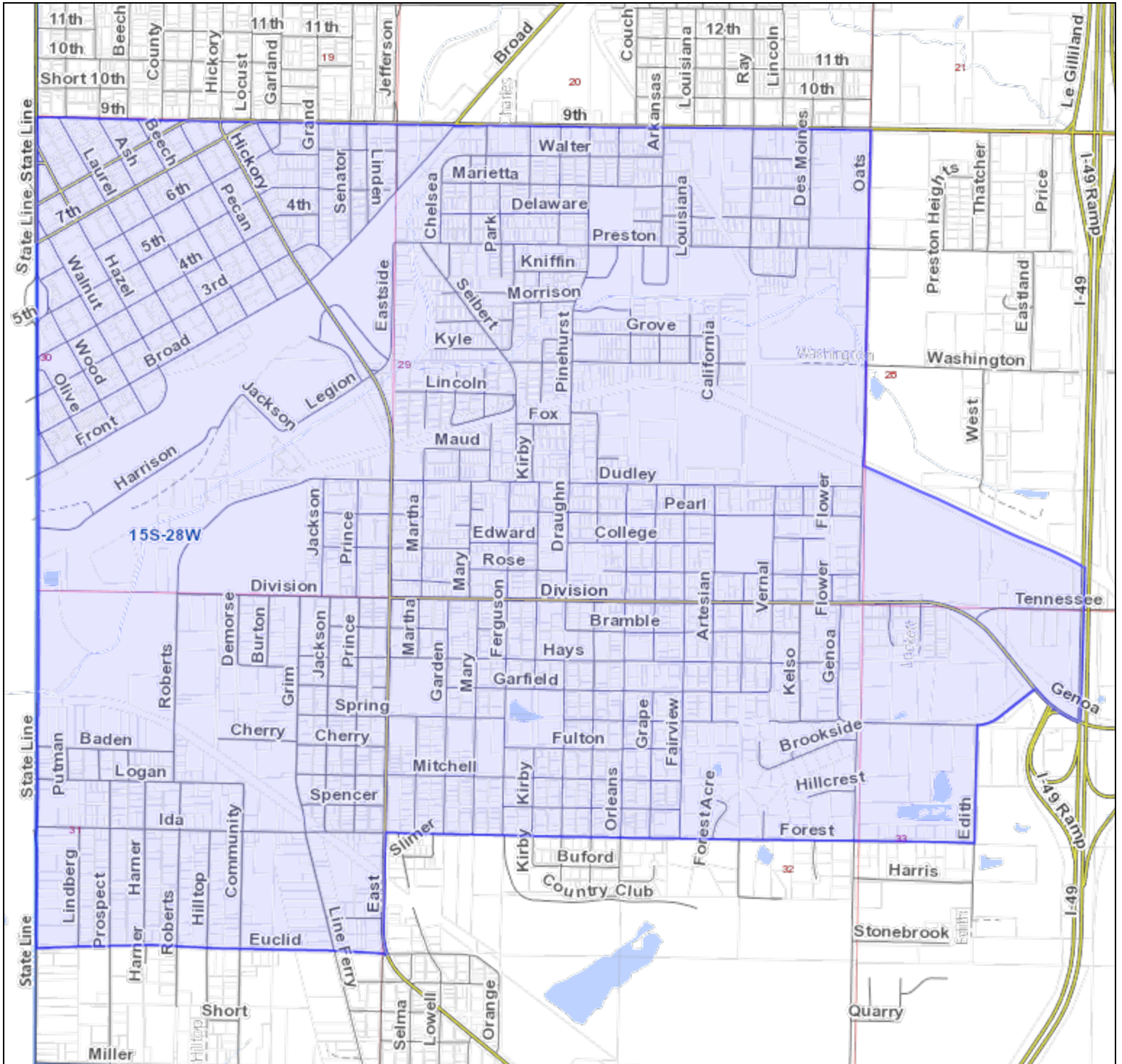

# Redistricting Final Report

## Texarkana City Council Wards

### District: 3

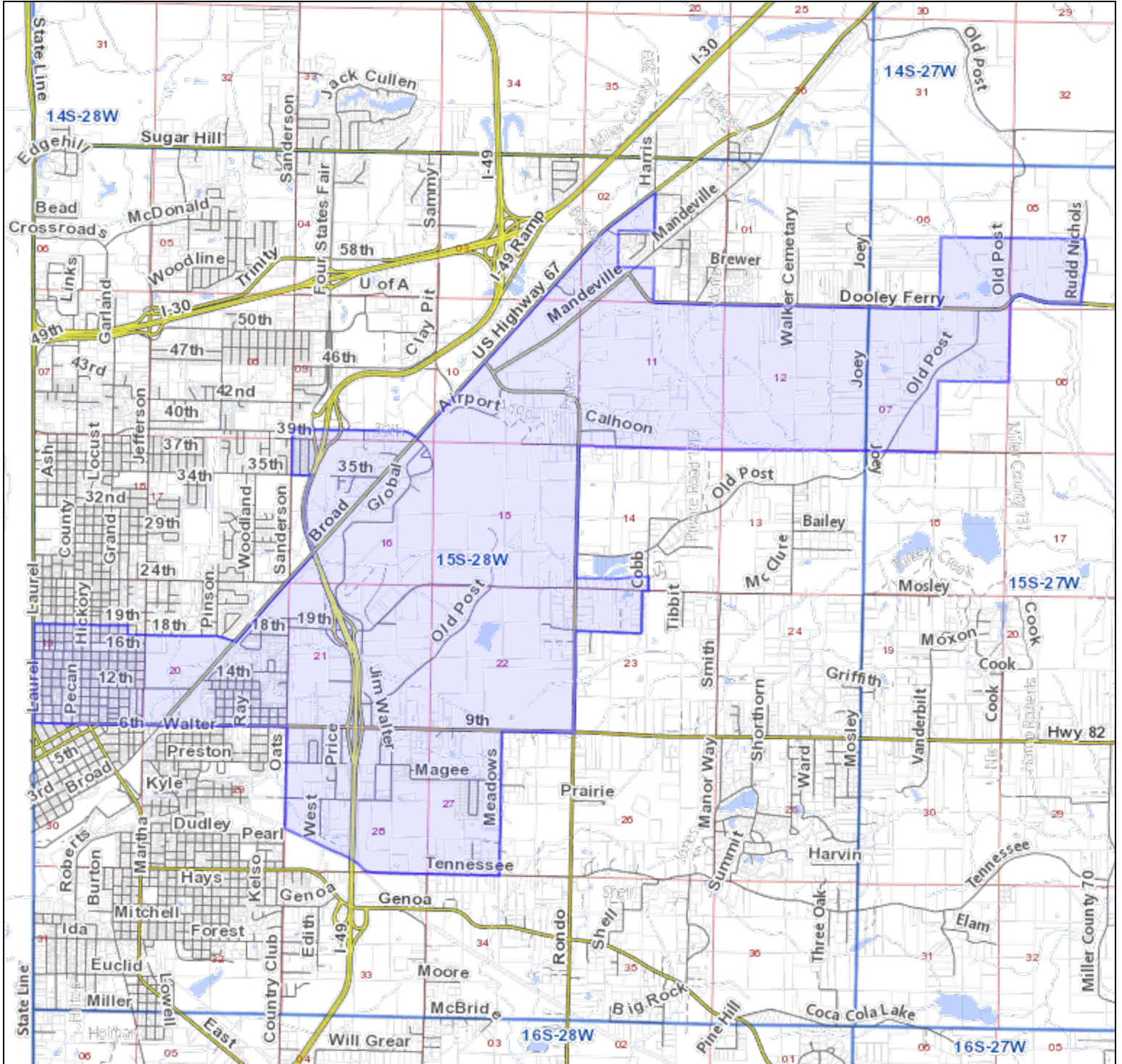



# Redistricting Final Report

## Texarkana City Council Wards

District: 4

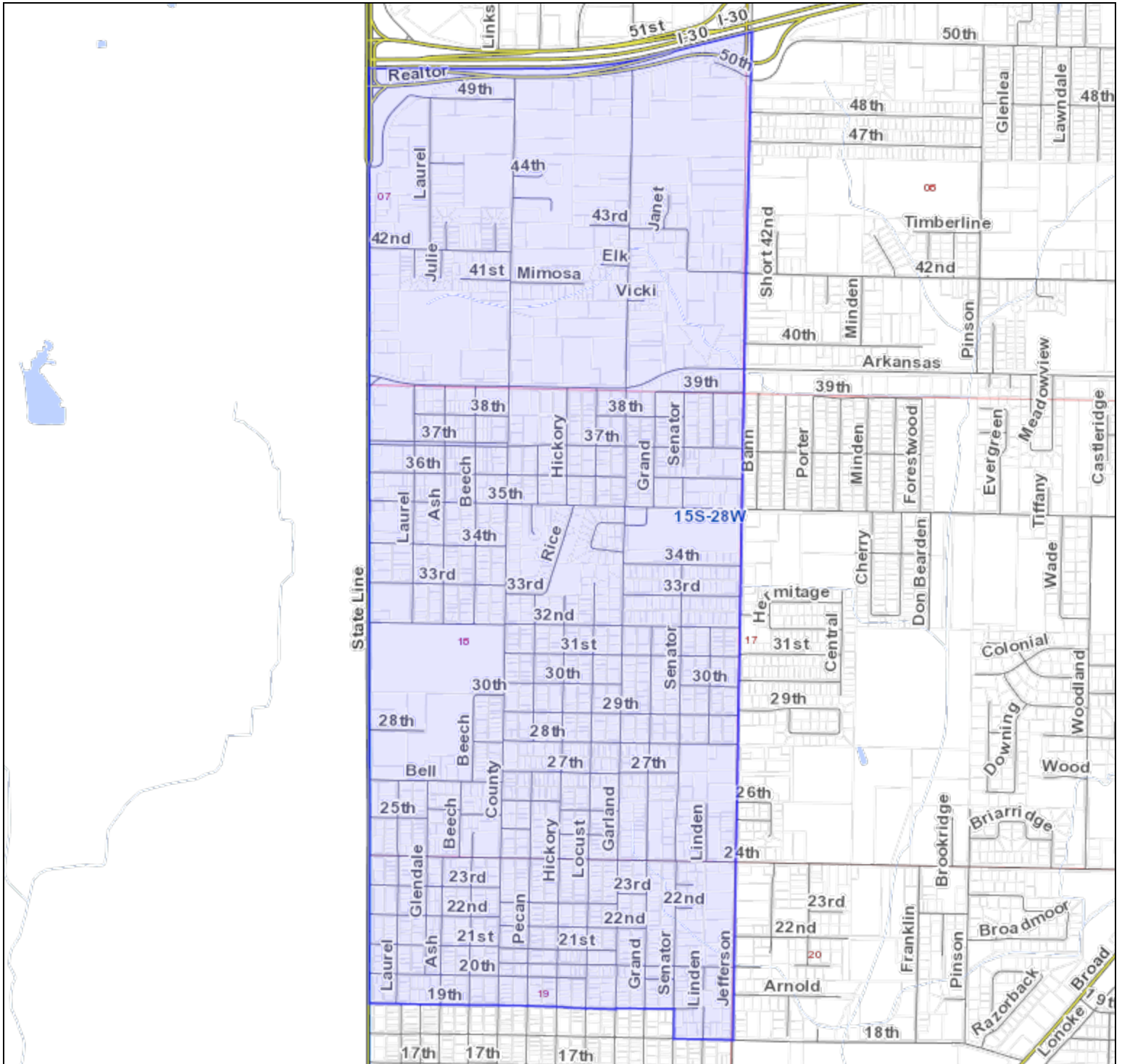

# Redistricting Final Report

## Texarkana City Council Wards

### District: 5

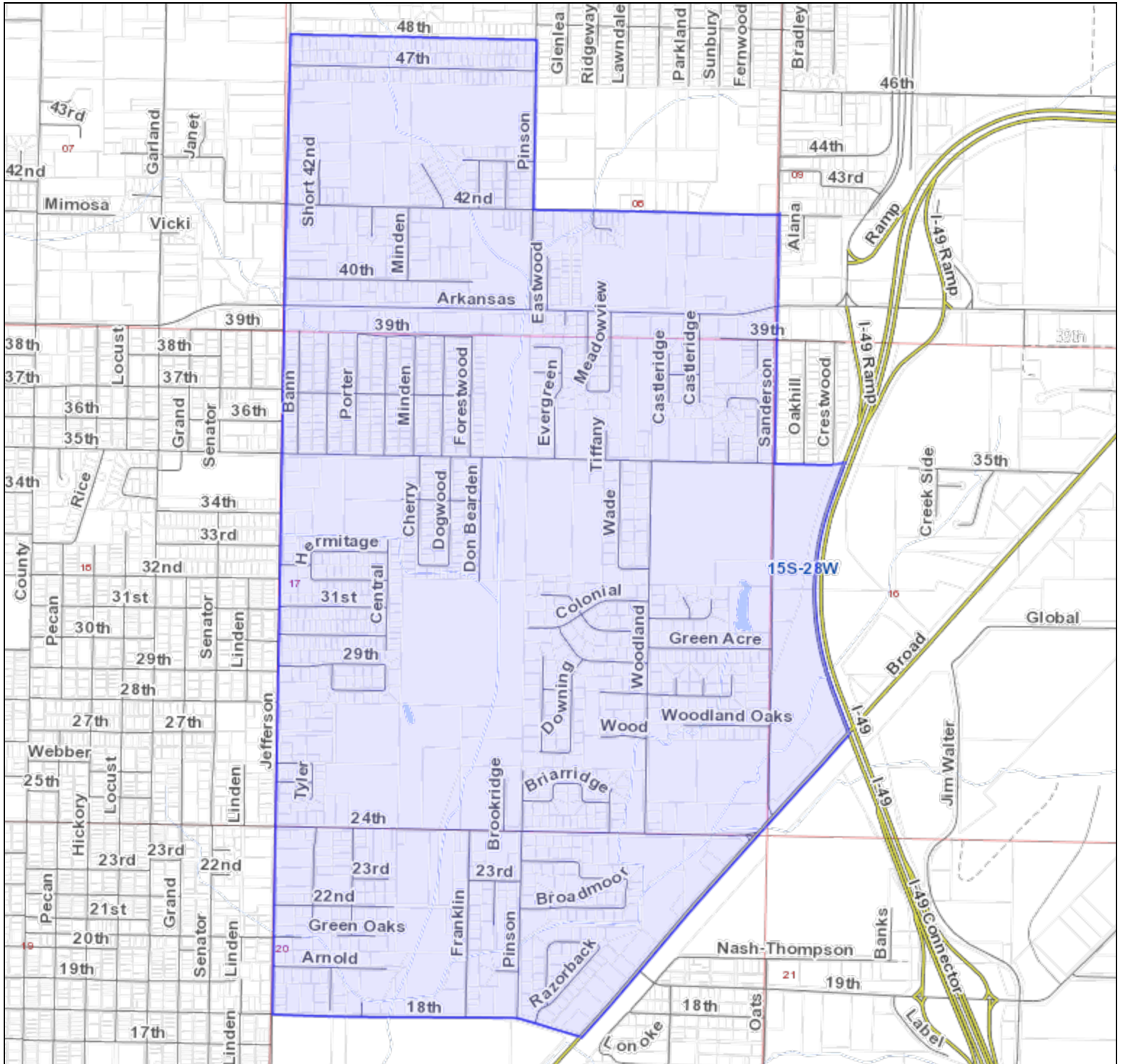

# Redistricting Final Report

Texarkana City Council Wards

## District: 6

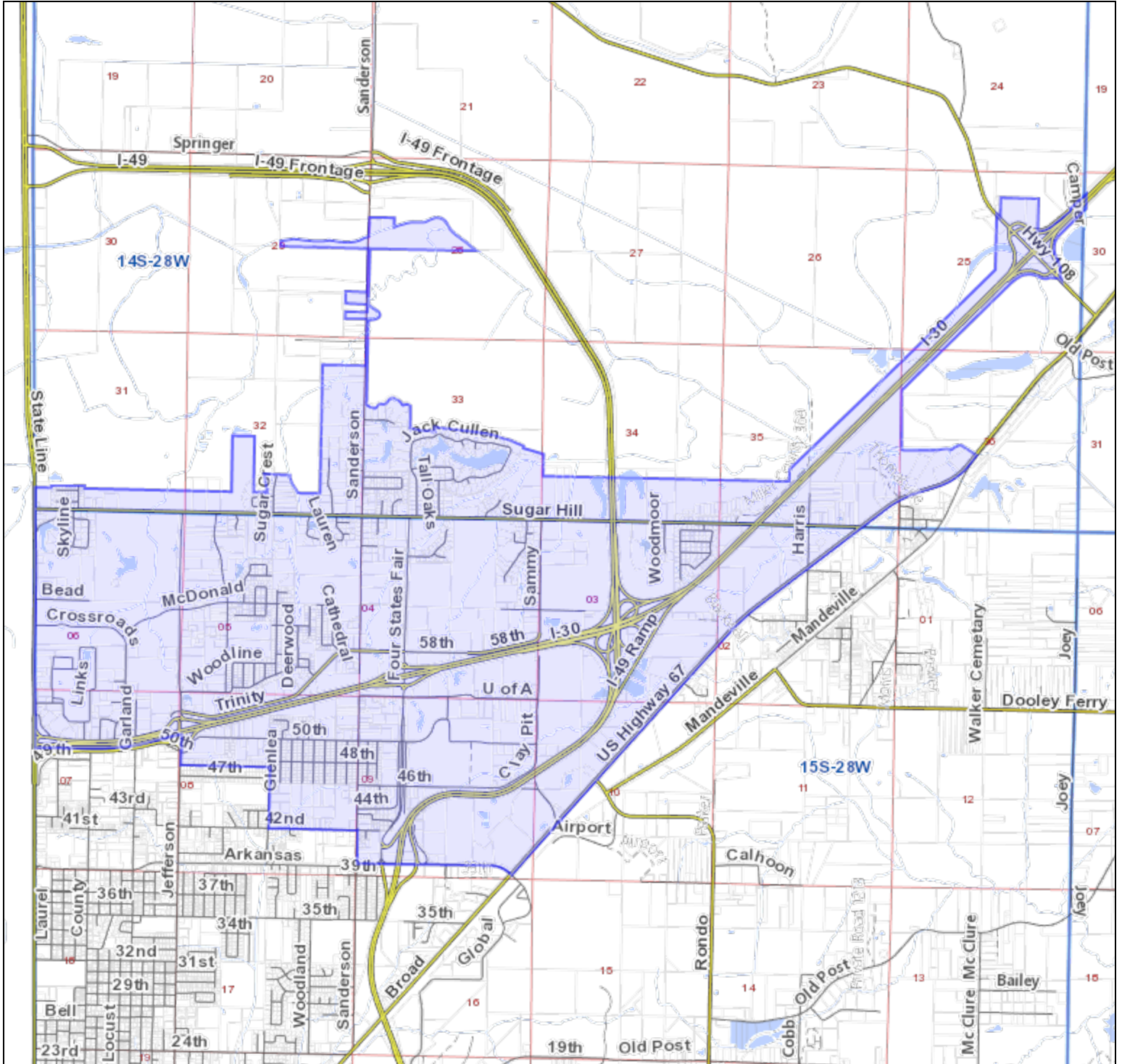

# Redistricting Final Report

Texarkana City Council Wards

## Adoption

Adopted this \_\_\_\_\_ day of \_\_\_\_\_, 2023 by \_\_\_\_\_.

\_\_\_\_\_  
Name

\_\_\_\_\_  
Name

\_\_\_\_\_  
Title

\_\_\_\_\_  
Title

\_\_\_\_\_  
Date

\_\_\_\_\_  
Date

\_\_\_\_\_  
Name

\_\_\_\_\_  
Name

\_\_\_\_\_  
Title

\_\_\_\_\_  
Title

\_\_\_\_\_  
Date

\_\_\_\_\_  
Date

### ATTEST:

\_\_\_\_\_  
Name

\_\_\_\_\_  
Title

\_\_\_\_\_  
Date



# CITY OF TEXARKANA, AR

## BOARD OF DIRECTORS

---

**AGENDA TITLE:** Adopt an Ordinance authorizing the Board of Directors to amend Section 17-4 of the *City of Texarkana, Arkansas, Code of Ordinances* and provide for certain new fees for the rental and use of Front Street Festival Plaza. (PARKS) Parks and Recreation Director Adam Dalby

*The applicant requests an emergency clause. An emergency clause requires a separate and distinct vote of the board and is valid only if there is a two-thirds vote of approval by the board. (Hdbk. Const. Amend 7)*

**AGENDA DATE:** May 15, 2023

**ITEM TYPE:** Ordinance  Resolution  Other :

**DEPARTMENT:** Parks and Recreation Department

**PREPARED BY:** Adam Dalby, Parks and Recreation Director

---

**REQUEST:** Adopt an Ordinance authorizing the Board of Directors to amend Section 17-4 of the *City of Texarkana, Arkansas, Code of Ordinances* and provide for certain new fees for the rental and use of Front Street Festival Plaza.

**EMERGENCY CLAUSE:** YES

---

**SUMMARY:** Authorizing the Board of Directors to amend Section 17-4 of the *City of Texarkana, Arkansas, Code of Ordinances* and provide for certain new fees for the rental and use of Front Street Festival Plaza.

The following fees are proposed for use of Front Street Festival Plaza and shall supersede any previously adopted fee for such:

### Proposed Front Street Festival Plaza Rental Rates

	For Profit Rates	Not For Profit Rates
Security Deposit: (refundable)	\$500.00	\$500.00
Cleaning Fee: (required)	\$500.00	\$500.00
Daily Rental- All Areas	\$2,000.00	\$1,500.00
Half Day Rental- All Areas	\$1,200.00	\$900.00
Daily Rental without Stage	\$1,000.00	\$800.00
Half Day Rental without stage	\$750.00	\$500.00
Daily Rental = 17 hours (Starting at 6AM)		
Half Day Rental = 6 hours		

---

<b>EXPENSE REQUIRED:</b>	\$0.00
<b>AMOUNT BUDGETED:</b>	\$0.00
<b>APPROPRIATION REQUIRED:</b>	\$0.00
<b>RECOMMENDED ACTION:</b>	Acting City Manager and staff recommend board approval.
<b>EXHIBITS:</b>	Ordinance and Fee Schedule

---

**Proposed Front Street Festival Plaza Rental Rates**

	<b>For Profit Rates</b>	<b>Not For Profit Rates</b>
Security Deposit: (refundable)	\$ 500.00	\$ 500.00
Cleaning Fee: (Required)	\$ 500.00	\$ 500.00
Daily Rental- All Areas	\$ 2,000.00	\$ 1,500.00
Half Day Rental- All Areas	\$ 1,200.00	\$ 900.00
Daily Rental without Stage	\$ 1,000.00	\$ 800.00
Half Day Rental without stage	\$ 750.00	\$ 500.00
Half Day Rental = 6 hours		

# ORDINANCE NO. \_\_\_\_\_

## AN ORDINANCE AMENDING SECTION 17-4 OF THE *CITY OF TEXARKANA, ARKANSAS CODE OF ORDINANCES* TO INCLUDE NEW FEES FOR USE OF FRONT STREET FESTIVAL PLAZA; FOR DECLARING AN EMERGENCY; AND FOR OTHER PURPOSES

WHEREAS, it is necessary to amend and adopt certain fees payable to the City of Texarkana, Arkansas, for certain services provided and use of certain public facilities offered by the City; and

WHEREAS, Section 17-4 of the *City of Texarkana, Arkansas, Code of Ordinances* (“Code”) provides for collection of fees for use of park facilities upon approval by the Board of Directors; and

NOW, THEREFORE, BE IT ORDAINED by the Board of Directors of the City of Texarkana, Arkansas, that the *City of Texarkana, Arkansas, Code of Ordinances* is amended as follows:

**Section 1.** In accordance with Section 17-4 of the *Code*, the following fees are adopted for the use of the following facilities and shall supersede any previously adopted fee (if applicable) for each of the following:

### Front Street Festival Plaza Rental Rates

	For Profit Rates	Not For Profit Rates
Security Deposit: (refundable)	\$500.00	\$500.00
Cleaning Fee: (required)	\$500.00	\$500.00
Daily Rental- All Areas	\$2,000.00	\$1,500.00
Half Day Rental- All Areas	\$1,200.00	\$900.00
Daily Rental without Stage	\$1,000.00	\$800.00
Half Day Rental without stage	\$750.00	\$500.00

Daily Rental = 17 hours  
Half Day Rental = 6 hours



**Section 2.** Except as specifically amended or adopted herein, all other fees heretofore adopted and approved by the Board of Directors or in accordance with applicable law remain unmodified. To the extent that any portion of this Ordinance is determined to be contrary to applicable law or otherwise unenforceable, such finding shall not affect any other provisions hereof and the same will remain in full force and effect from and after the effective date of this ordinance.

**Section 3.** This action being necessary for the preservation of the public peace, health and safety (including, without limitation, the need to implement the adopted fees described herein to set a budget for FY2024), and a separate and distinct vote having been taken on this emergency clause, an emergency is therefore declared to exist, and this ordinance shall be in full force and effect from and after its passage and approval.

**PASSED AND APPROVED** this 15<sup>th</sup> day of May, 2023.

---

Allen L. Brown, Mayor

**ATTEST:**

---

Heather Soyars, City Clerk

**APPROVED:**

---

Joshua L. Potter, City Attorney